

**MIE**  
and  
my  
Loose  
Furniture

**MisuraEmme®**



# SOMMARIO

## INDEX

Rigore e purezza, design contemporaneo e funzionalità.  
 Un connubio perfetto dal quale scaturisce una nuova estetica del vivere  
 odierno, capace di scandire con armonia encomiabile i luoghi dell'abitare.  
 Geometrie lineari e volumi scultorei modulano lo spazio, diventato  
 a misura di sé, palcoscenico in cui l'imperativo della qualità,  
 dell'innovazione e dell'attenzione ai dettagli diventano i rappresentanti  
 di un glamour e di un fascino senza tempo.

*Precision, purity, contemporary design and functionality.  
 A perfect combination that gives rise to a new contemporary lifestyle  
 aesthetic, lending remarkable harmony to living environments.  
 Linear geometry and sculptural volumes modulate space that has become  
 self-defining, a stage on which high quality, innovation and attention  
 to detail represent glamour and timeless charm.*



**Divani**  
*Sofas*

—  
04



**Divanetti**  
*Small sofas*

—  
62



**Poltrone**  
*Armchairs*

—  
86



**Sedie**  
*Chairs*

—  
122



**Tavoli**  
*Tables*

—  
158



**Consolle e scrittoi**  
*Console and writing desks*

—  
194



**Tavolini**  
*Small tables*

—  
206



**Madie**  
*Sideboards*

—  
260



**Letti**  
*Beds*

—  
296



**Complementi notte**  
*Night complements*

—  
338



**Accessori**  
*Accessories*

—  
366

# DIVANI SOFAS

Volumi scultorei modulano lo spazio living abbracciandolo con sobria eleganza e creando un micro cosmo perfetto nel quale portare in scena la quotidianità del vivere gli spazi di casa. Affusolati, dall'armonia ricercata tra forme e materiali e contraddistinti da una totale libertà compositiva, pensata per accogliere elementi accessori, braccioli e schienali.

*Sculptural designs bring structure to living areas, injecting understated elegance and creating the perfect setting for day-to-day domestic life. Striking a sophisticated balance between carefully designed shaping and the finest materials, these sofas showcase absolute freedom of expression, with perfect continuity between accessories, armrests and backrests.*



**Rosè**  
Studio 63

---

06



**Argo**  
Mauro Lipparini

---

22



**Cannes**  
Ferruccio Laviani

---

44

# ROSE

DESIGN: STUDIO 63

Il divano Rosè è costituito da elementi modulari che, con il loro design organico, offrono versatilità compositiva che si traduce in una forma sempre nuova e mai banale. La declinazione dei moduli, composta anche da chaise longue, pouf e tavolino, copre tutte le esigenze di qualsiasi spazio abitativo. Questo oggetto scultoreo vive di luce propria grazie alle sue forme abbondanti che rappresentano la volontà dello Studio63 di creare un sistema organico dai contorni morbidi e senza tempo.

*The Rosè sofa is composed of modular elements that, with their organic design, offer compositional versatility, resulting in a form that is always fresh and never mundane. The range of modules, including chaise longue, ottoman, and coffee table, covers all the needs of any living space. This sculptural object has its own lightness thanks to its abundant shapes, representing Studio63's desire to create an organic system with timeless and soft contours.*











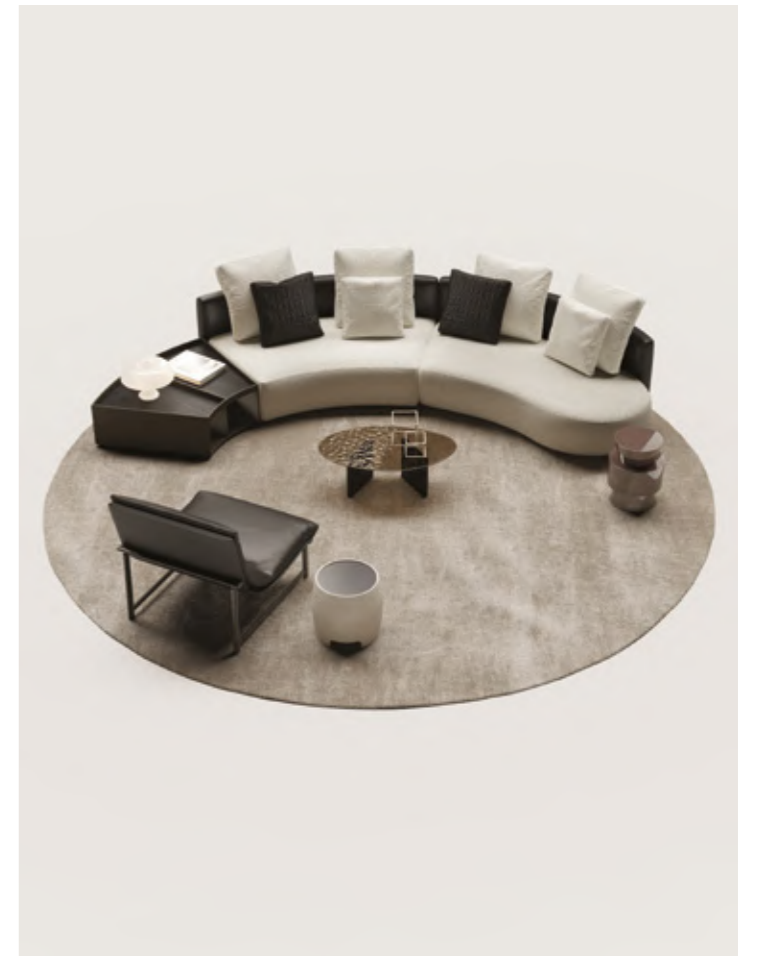





**ROSÈ: DIVANO COMPONIBILE \_ MODULAR SOFA**

Il sistema divani Rosè è disponibile in versione componibile caratterizzato dalle molteplici possibilità di composizioni, costituito da elementi base accostabili per formare composizioni lineari e angolari.

La struttura in legno multistrato è rivestita da uno strato di poliuretano flessibile stampato, dotato di piedini H.40mm. in PVC.

Il cuscino di seduta è in poliuretano espanso sagomato a quote differenziate ricoperto in fibra di poliestere, mentre lo schienale è in fibra di poliestere rivestito in fodera di cotone.

Il rivestimento finale è disponibile in tessuto, ecopelle o pelle; tutte le tipologie di rivestimento sono sfoderabili. È disponibile la variante bicolor con finiture diverse per il rivestimento dello schienale e della seduta.

Il tavolino è indipendente dai divani e può essere collocato senza vincoli. Struttura in metallo verniciato Canna di fucile e piano disponibile in essenza opaca in tutte le finiture.

*The modular Rosè sofa system characterized by multiple composition possibilities, consisting of base elements that can be combined to create linear and corner configurations.*

*The structure is made of wood and plywood covered with a layer of molded flexible polyurethane, equipped with h. 40 mm PVC feet.*

*The seat cushion is made of shaped polyurethane foam with differentiated densities, covered in polyester fiber, while the backrest is made of polyester fiber with a cotton lining.*

*The final upholstery is available in fabric, eco-leather, or leather; all upholstery types are removable. A bicolor variant is available, featuring different finishes for the backrest and seat upholstery.*

*The side table is independent from the sofas and can be placed freely. Its structure is made of varnished Gunmetal, with a top available in matt wood veneer, all finishes.*

**BRACCIOLO \_ ARMREST**

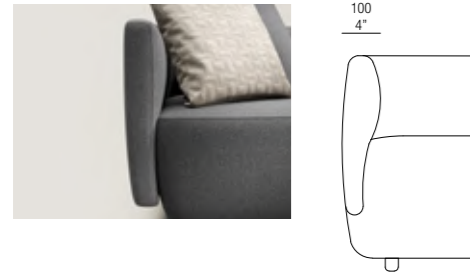

**CUSCINI \_ CUSHIONS**

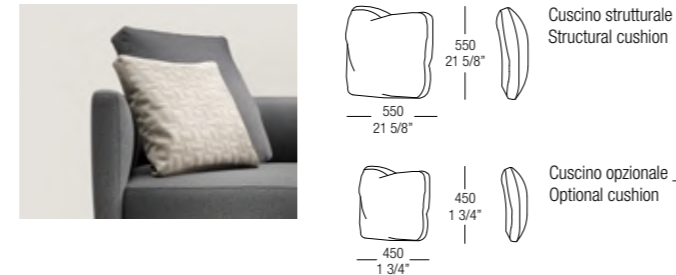

**ELEMENTI COMPONIBILI: ELEMENTI INIZIALI E TERMINALI \_ MODULAR ELEMENTS: INITIAL AND TERMINAL ELEMENTS**

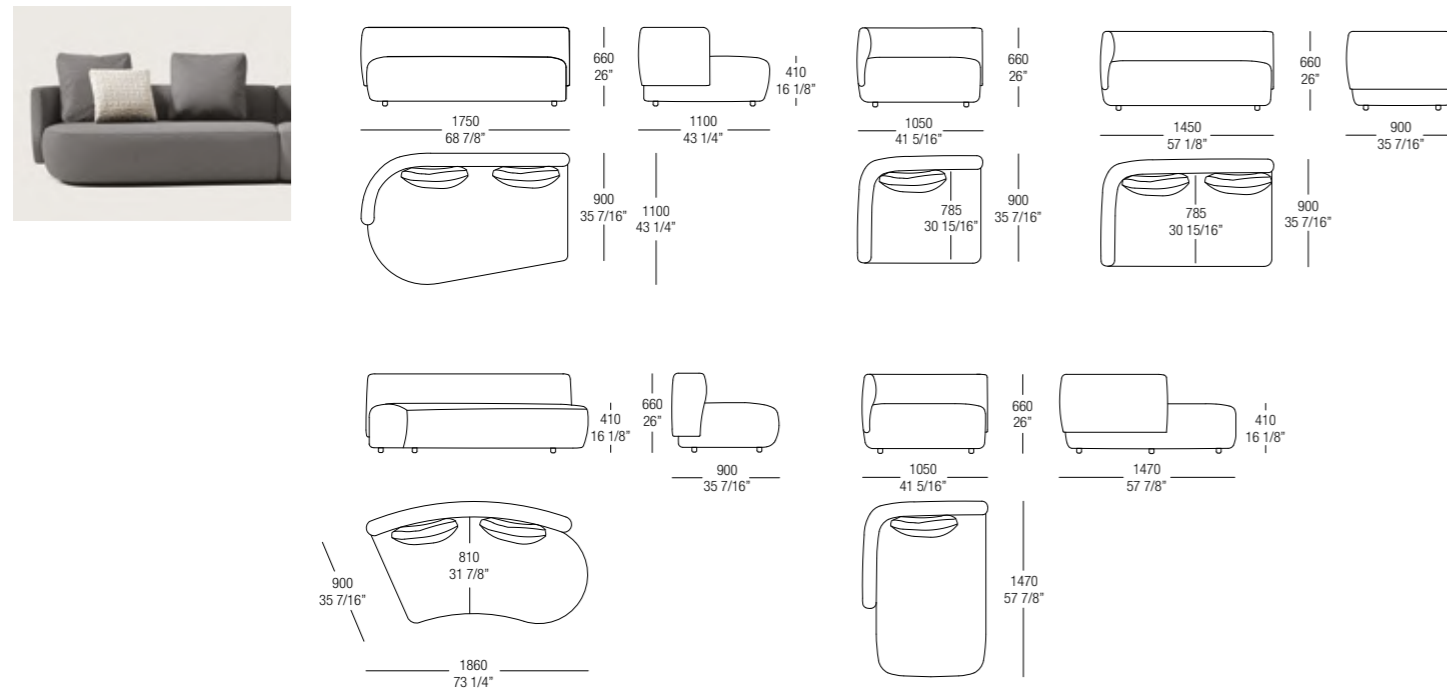

**ELEMENTI COMPONIBILI: ELEMENTI CENTRALI \_ MODULAR ELEMENTS: CENTRAL ELEMENTS**

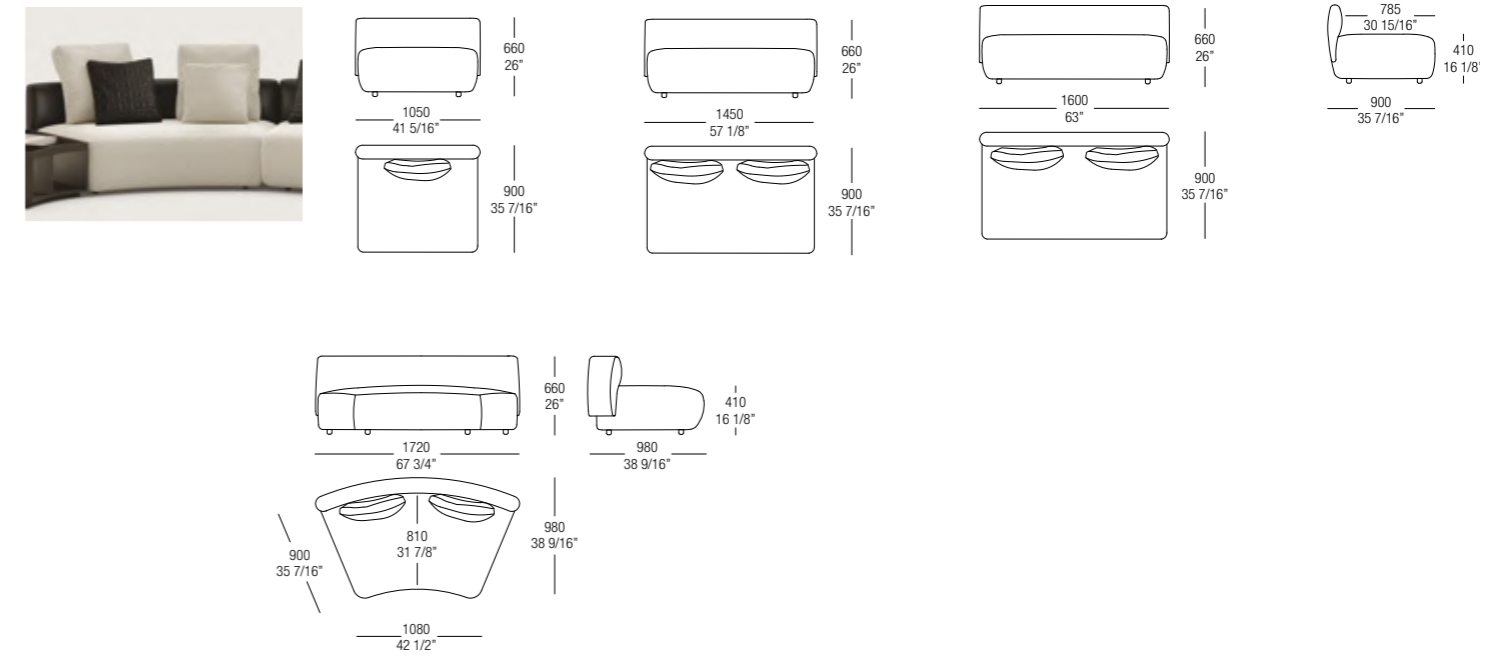

**POUF**

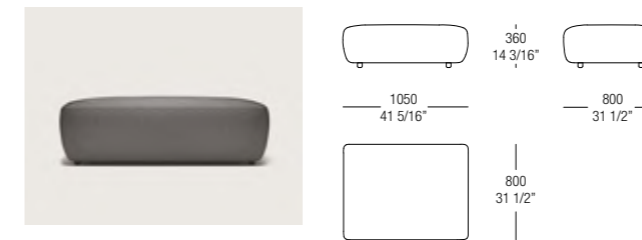

**TAVOLINO \_ SIDE TABLE**

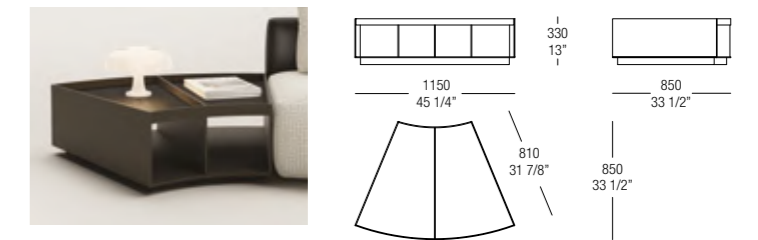

# ARGO

DESIGN: MAURO LIPPARINI

Una zona living tailor-made in cui armonia ed estetica su misura trovano la loro massima espressione. Con la sua forma a "C", il divano Argo riempie lo spazio circostante con soluzioni fortemente personalizzate grazie all'alternarsi degli elementi podio-contenitori. Un perfetto equilibrio tra forme e materiali.

*Perfect for a unique living room based around balance and bespoke aesthetics, the C-shaped Argo sofa fills the space with its fully customisable set-up thanks to a succession of storage/pedestal elements. An unbeatable mix of good design and the best materials.*





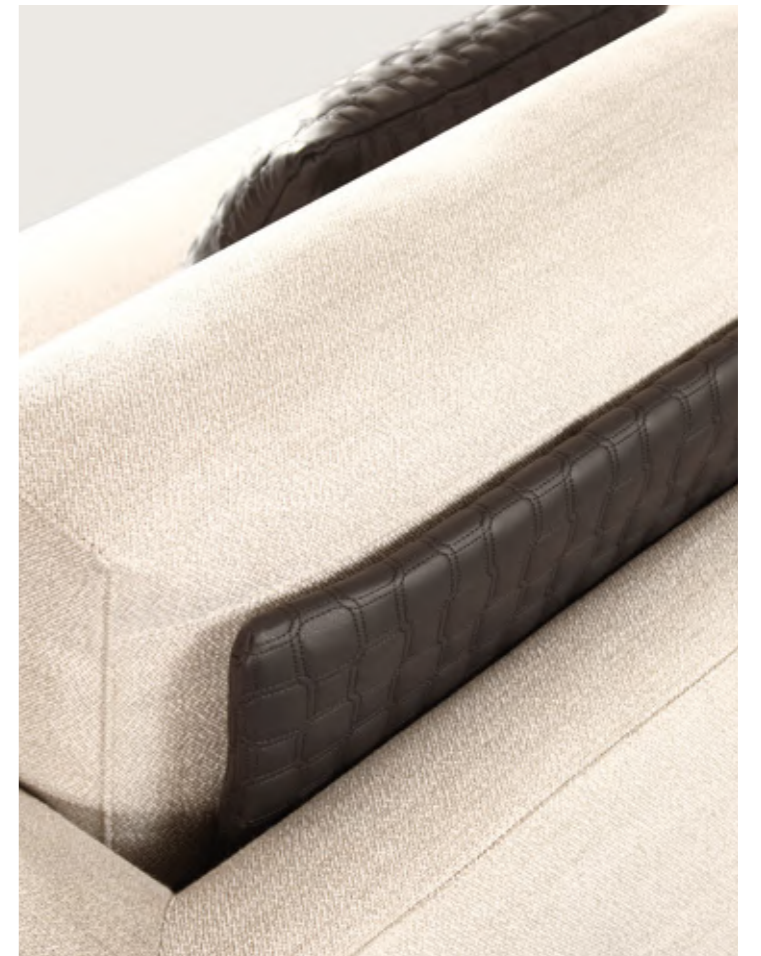







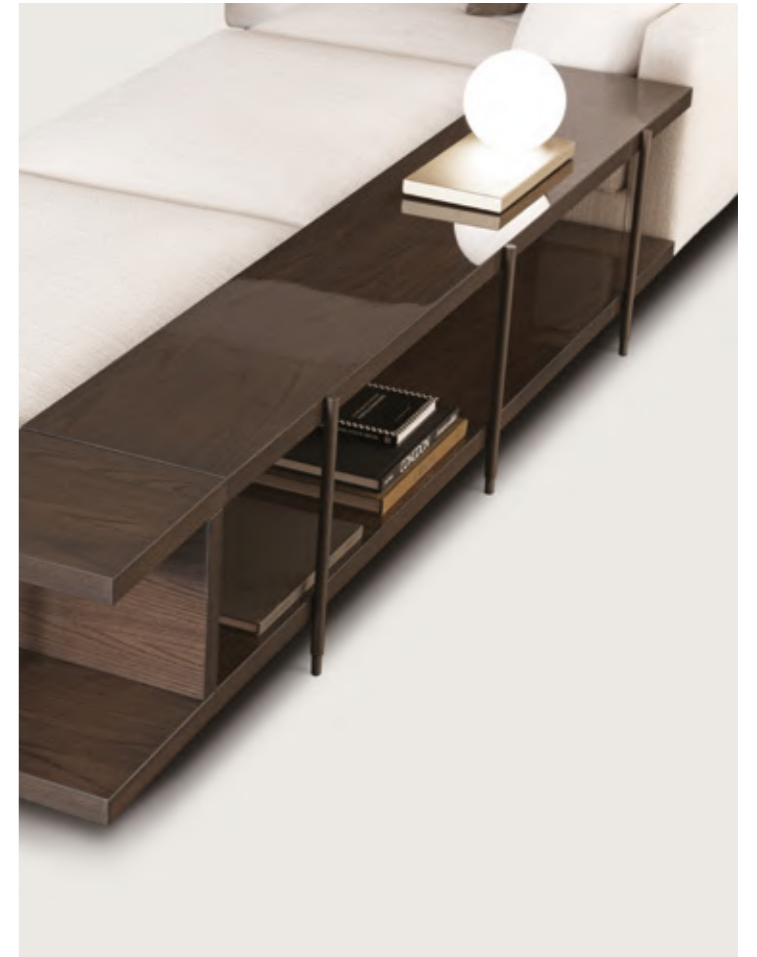



**ARGO: DIVANO COMPONIBILE \_ MODULAR SOFA**

Il sistema divano Argo è disponibile in versione componibile caratterizzato dalle molteplici possibilità di composizioni, costituito da moduli centrali, terminali, angolari con braccioli o piani di appoggio, accostabili tra loro per formare composizioni ad angolo o lineari.

La struttura è in legno multistrato rivestita da uno strato di poliuretano flessibile stampato, dotato di piedini H.80 mm, in metallo opaco Canna di fucile.

Il cuscino di seduta è in poliuretano espanso sagomato a quote differenziate ricoperto in fibra di poliestere, mentre il cuscino schienale è in fibra di poliestere e piuma sterilizzata, entrambi rivestiti in fodera di cotone, dotato di struttura in metallo finalizzata a migliorarne il comfort.

Il rivestimento finale è disponibile in tessuto, ecopelle o pelle sfoderabile. È disponibile la variante bicolore con finiture diverse per il rivestimento dell'inserto retro-cuscino con possibilità di trapuntatura per le finiture pelle e nabuk.

I braccioli sono disponibili in diverse dimensioni: L.100 mm, L. 300 mm e con l'elemento di appoggio in essenza opaca e lucida nelle finiture Rovere nero, Olmo Grey, Tabacco, Eucalipto ed Ebano.

Nella collezione Argo fa parte anche l'elemento libreria, indipendente dal divano. Esso è composto da particelle di legno sp. 38 mm. e disponibile nelle finiture laccato opaco e lucido ed essenza Rovere nero, Olmo Grey, Eucalipto, Ebano, Noce Canaletto e Tabacco.

*The Argo sofa system is available in a modular version, characterized by multiple composition possibilities, consisting of central modules, terminal units, and corner pieces with armrests or support surfaces, which can be combined to form either corner or linear arrangements.*

*The structure is made of plywood covered with a layer of flexible molded polyurethane, with h. 80 mm feet in varnished Gunmetal finish.*

*The seat cushion is made of shaped polyurethane foam with varying densities, covered with polyester fiber, while the back cushion is filled with polyester fiber and sterilized down, both covered with cotton covers and equipped with a metal structure to improve comfort.*

*The final cover is available in fabric, eco-leather, or removable leather. A bicolor version is available with different finishes for the back cushion insert, with the option for quilting for leather and nabuk finishes.*

*Armrests come in different sizes: 100mm, 300mm, and with a support element in matt and glossy wood finishes of Black Oak, Grey Elm, Tobacco, Eucalyptus and Ebony.*

*The Argo collection also includes a bookshelf element, independent from the sofa. It is made of th. 38mm panels and available in matt and glossy lacquered finishes as well as in Black Oak, Grey Elm, Eucalyptus, Ebony, Canaletto Walnut, and Tobacco wood finishes.*

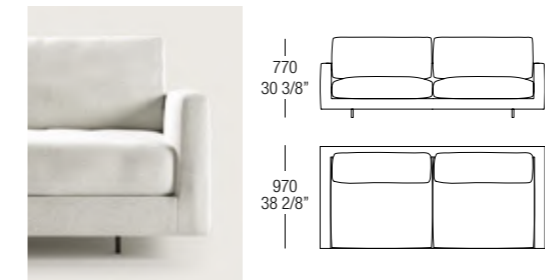
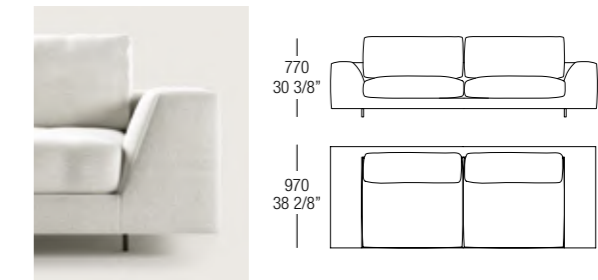
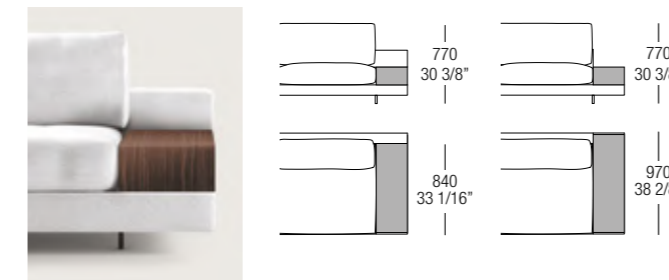
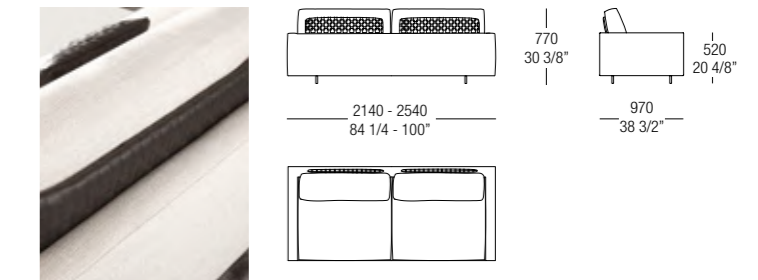
**DIVANI CON BRACCIOLO L.100 \_ SOFAS WITH ARMREST W.100****DIVANI CON BRACCIOLO L.300 \_ SOFAS WITH ARMREST W.300****DIVANI CON PIANO P.840 \_ SOFAS WITH TOP D.840****INSERTO RETRO CUSCINO \_ BACK CUSHION INSERT**

DIVANI FISSI \_ FIXED SOFAS

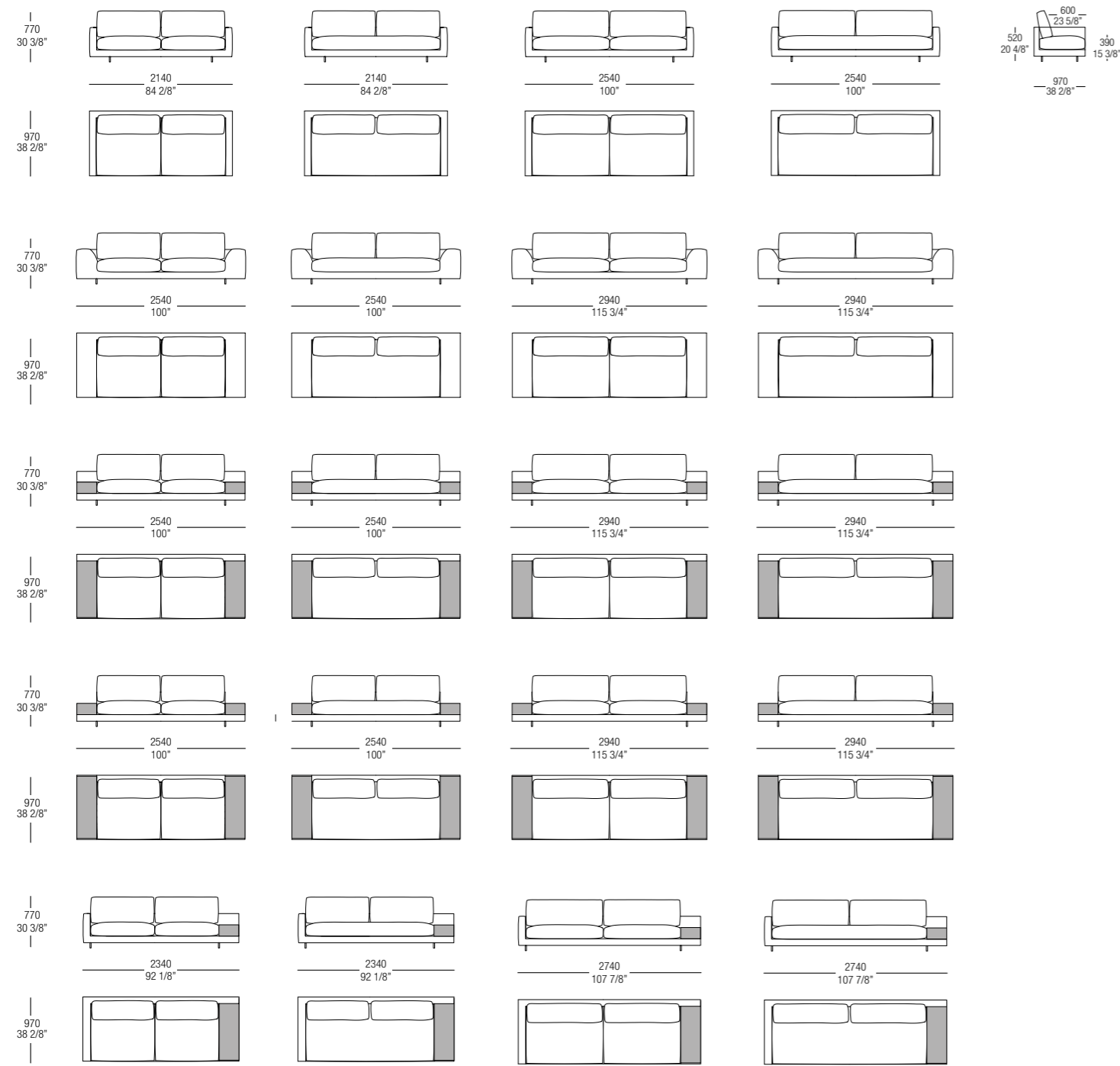

DIVANI FISSI: INCLINATI 30° \_ FIXED SOFAS: 30° INCLINED

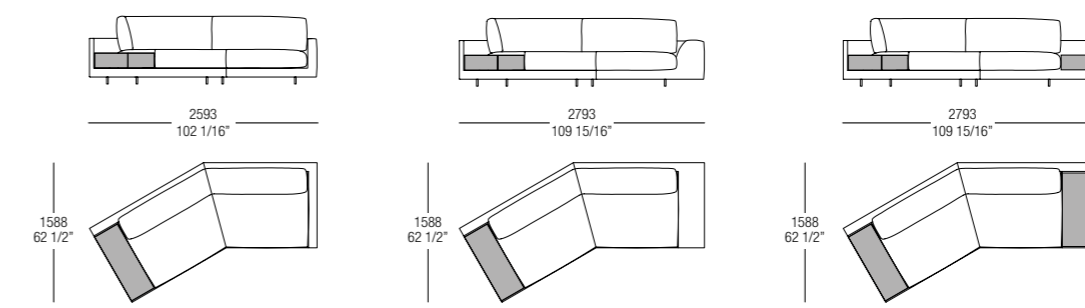

ELEMENTI COMPONIBILI: ELEMENTI CENTRALI \_ MODULAR ELEMENTS: CENTRAL ELEMENTS

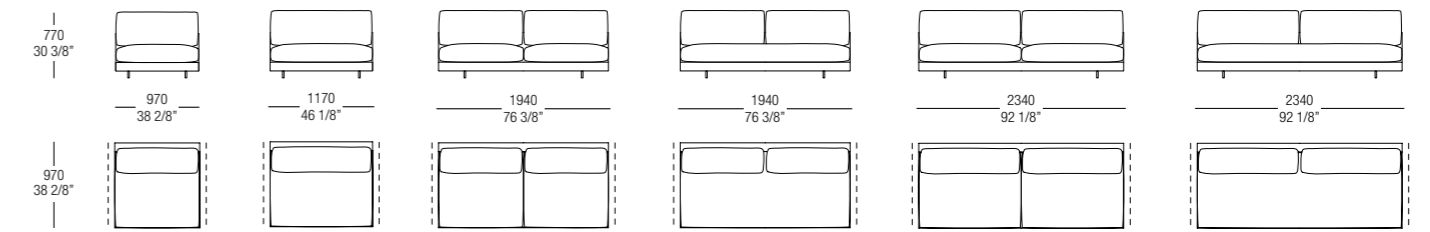

ELEMENTI COMPONIBILI: ELEMENTI TERMINALI \_ MODULAR ELEMENTS: TERMINAL ELEMENTS

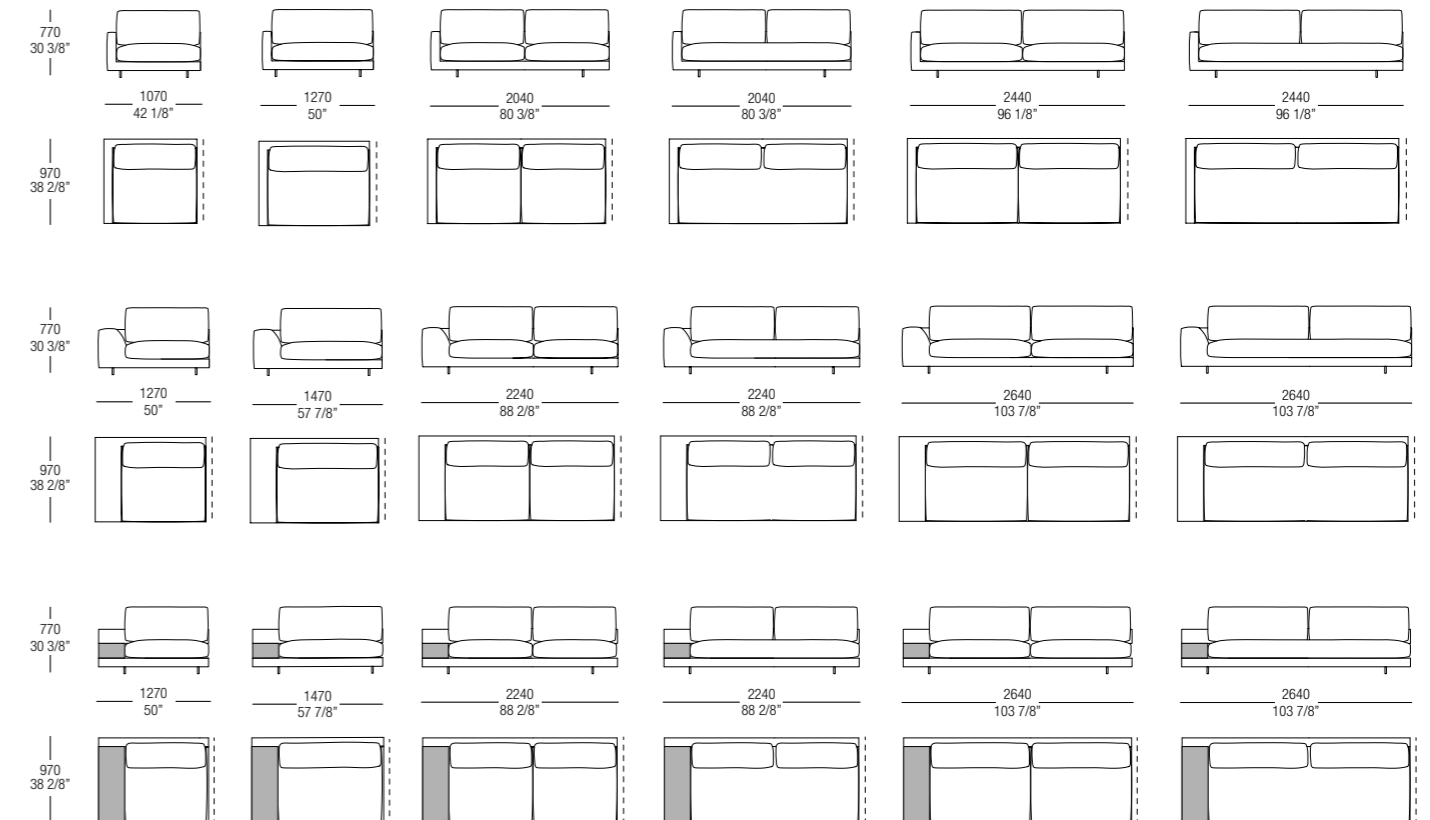

ELEMENTI COMPONIBILI: ELEMENTI ANGOLARI \_ MODULAR ELEMENTS: CORNER ELEMENTS

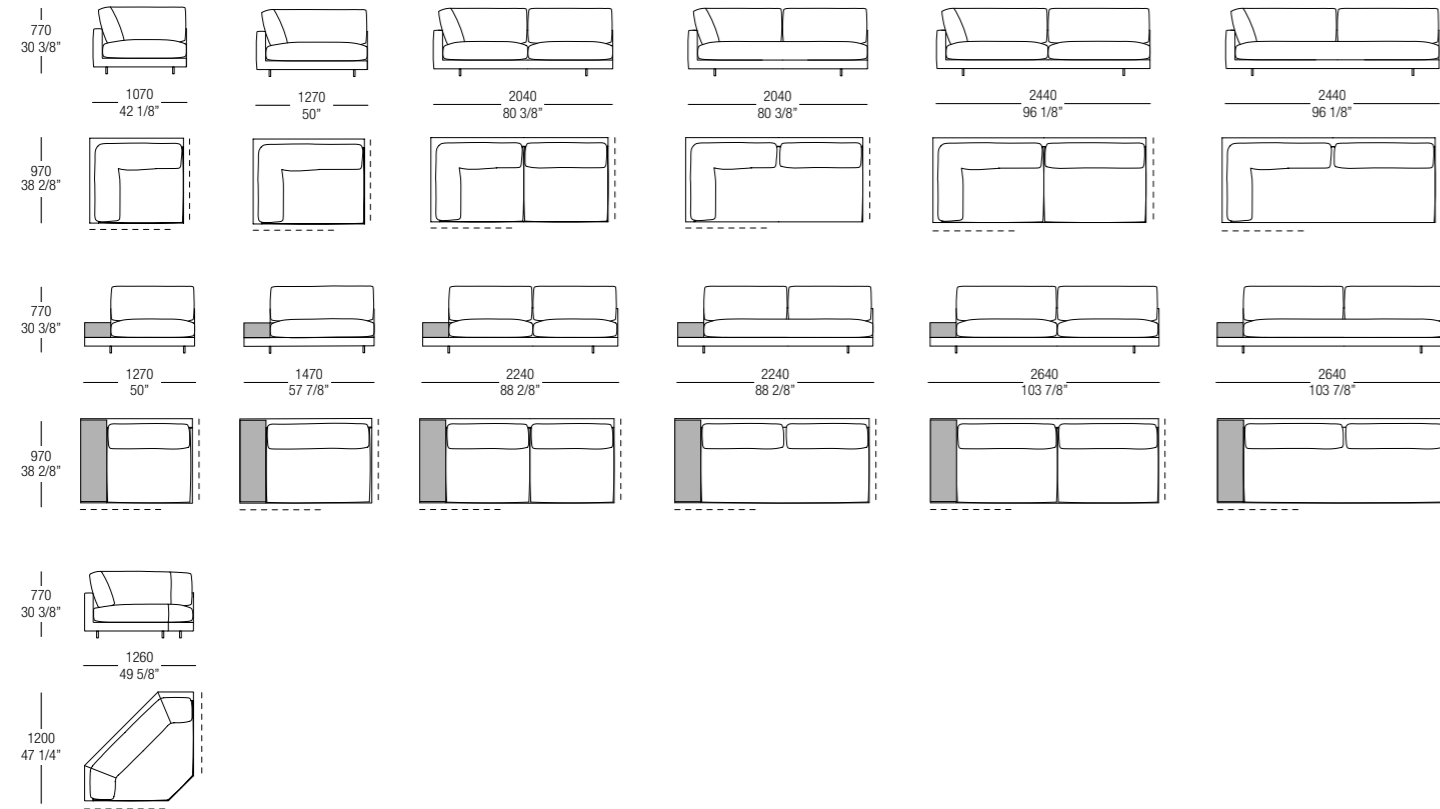

ELEMENTI COMPONIBILI: ELEMENTI INCLINATI 30° \_ MODULAR ELEMENTS: 30° INCLINED ELEMENTS

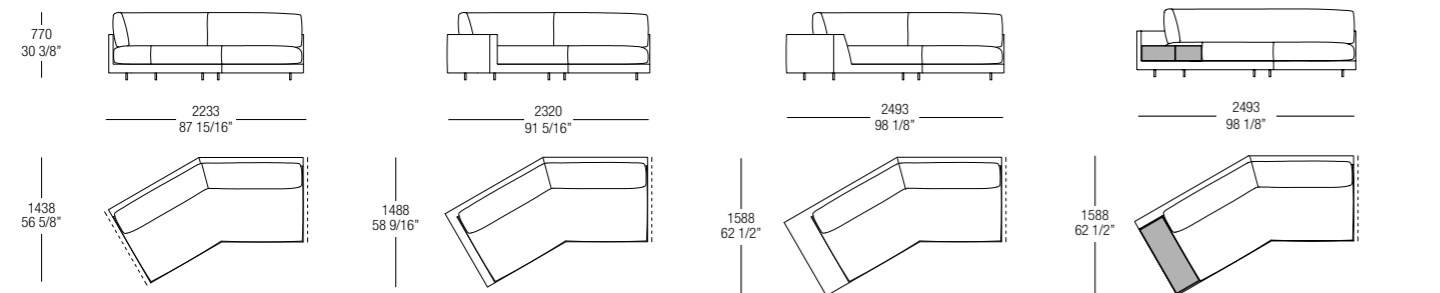

ELEMENTI COMPONIBILI: ELEMENTI ANGOLARI/TERMINALI \_ MODULAR ELEMENTS: CORNER/TERMINAL ELEMENTS

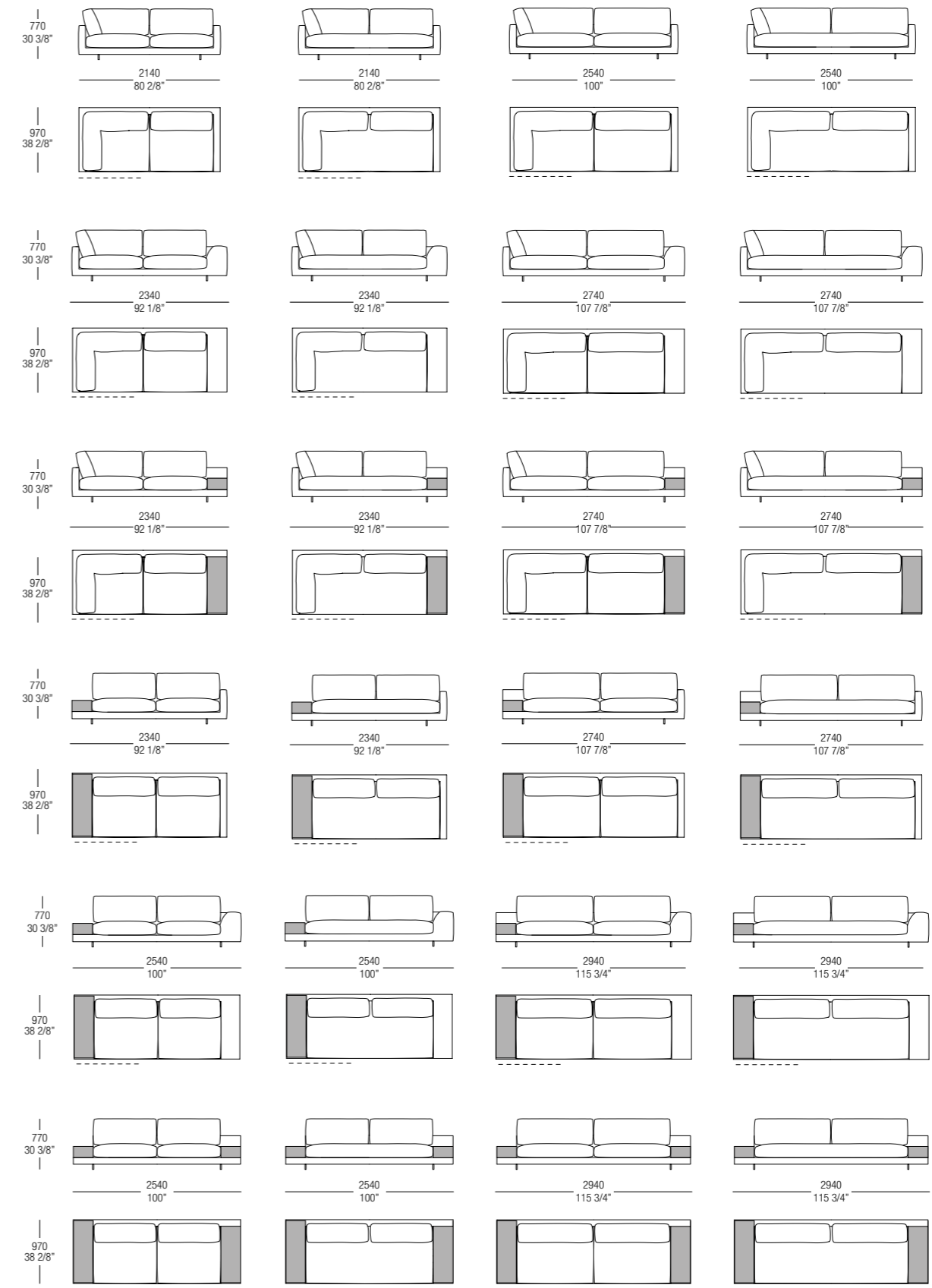

ELEMENTI COMPONENTI: CHAISE LOUNGUE \_ MODULAR ELEMENTS: CHAISE LOUNGUE

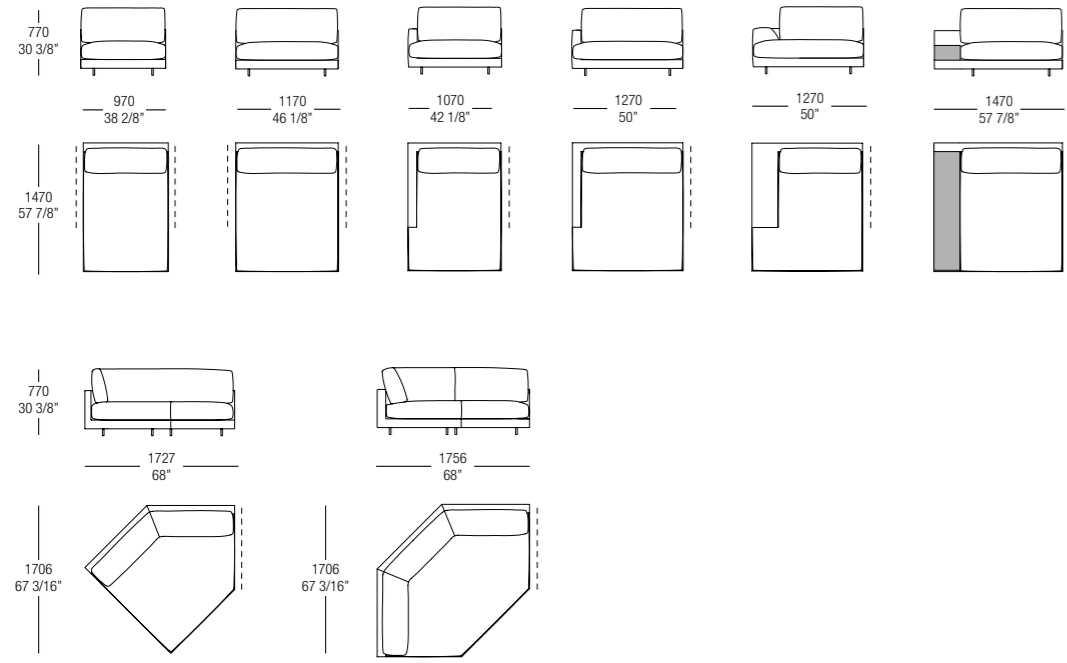

ELEMENTI COMPONENTI: POUF \_ MODULAR ELEMENTS: POUF

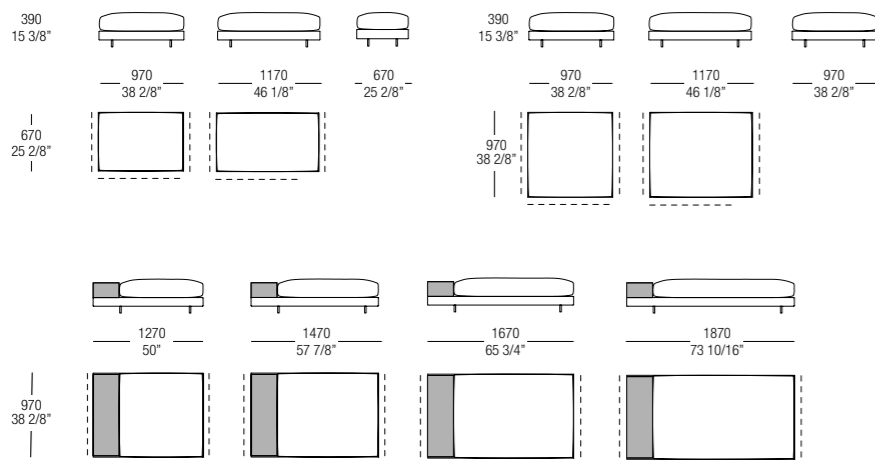

ELEMENTI COMPONENTI: CUSCINO \_ MODULAR ELEMENTS: CUSHION

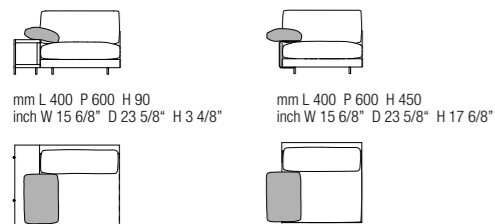

ELEMENTI COMPONENTI: LIBRERIA \_ MODULAR ELEMENTS: BOOKCASE

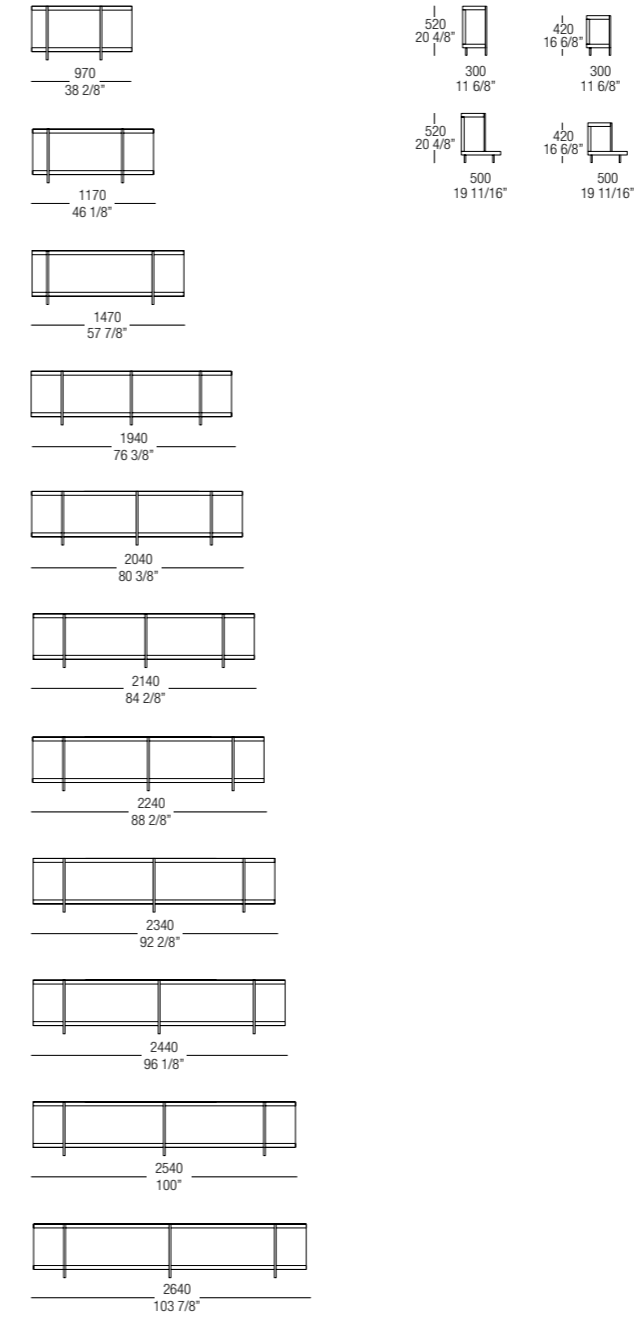

# CANNES

DESIGN: FERRUCCIO LAVIANI

Una famiglia di elementi aggregabili tra di loro vanno a creare il divano Cannes. Un grande gioco di forme libere, da accostare in base al proprio gusto dando vita a soluzioni ogni volta differenti. Stile e funzionalità diventano le cifre distintive di questo divano attuale e dal design contemporaneo.

*The Cannes sofa is more like a collection of different elements that can be connected up to create a whole. These freestanding parts can be mixed and matched to suit each owner's taste, ensuring no two solutions are ever the same. Style and practicality are the watchwords of this contemporary sofa.*





















**CANNES: DIVANO COMPONIBILE \_ MODULAR SOFA**

Il sistema di divani Cannes è disponibile in versione componibile caratterizzato dalle molteplici possibilità di composizioni, costituito da elementi base accostabili per formare composizioni lineari e angolari. La struttura portante è in legno con cinghie elastiche, ricoperta con poliuretano espanso a densità differenziate e materassina in piuma sulla seduta e schienale. La struttura metallica, porta bracciolo o porta piano d'appoggio e i piedini H.64 mm, è in metallo verniciato opaco Canna di fucile.

Rivestimento in tessuto sfoderabile da personale esperto o in pelle non sfoderabile. Piano appoggio disponibile nella finitura laccato opaco in tutte le varianti.

*The Cannes sofa system is available in a modular version, characterized by multiple composition possibilities, consisting of base elements that can be combined to form linear and corner arrangements. The supporting structure is made of wood with elastic webbing, covered with polyurethane foam of varying densities, and a mattress in down on the seat and backrest. The metal frame that supports the armrest or top support and the H.64 mm. feet is made of matt Gunmetal varnished.*

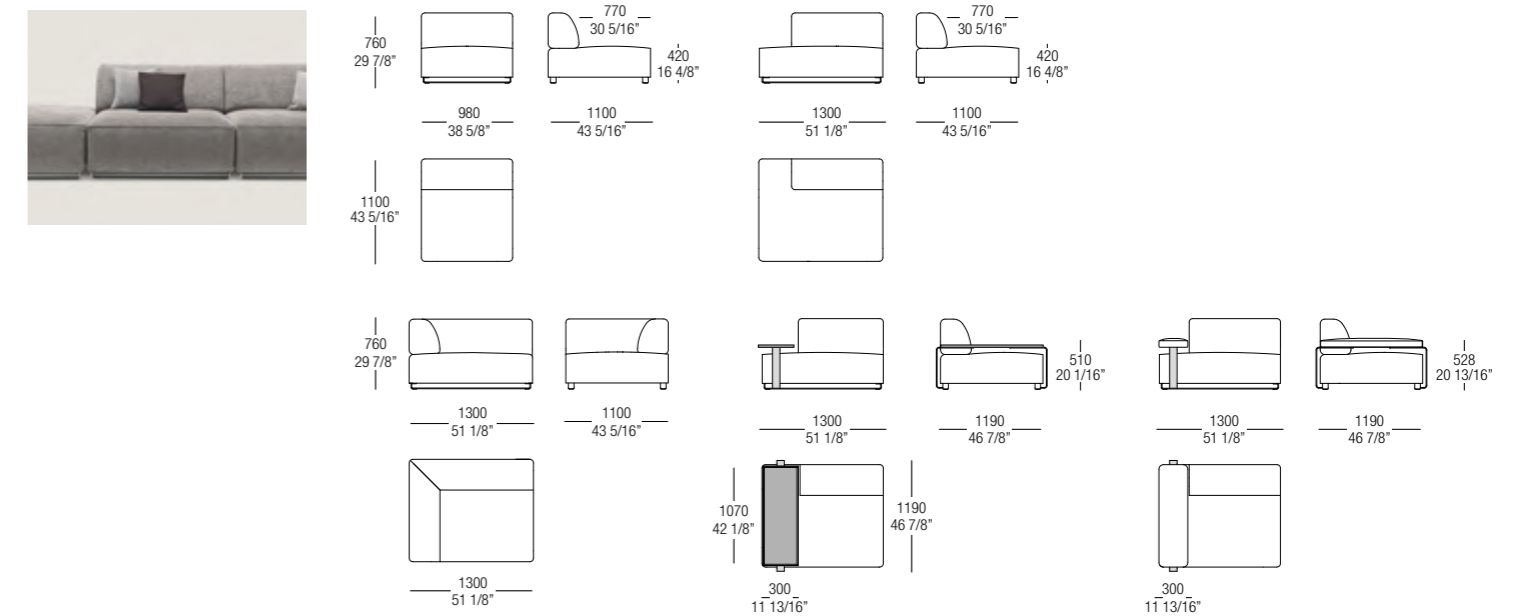
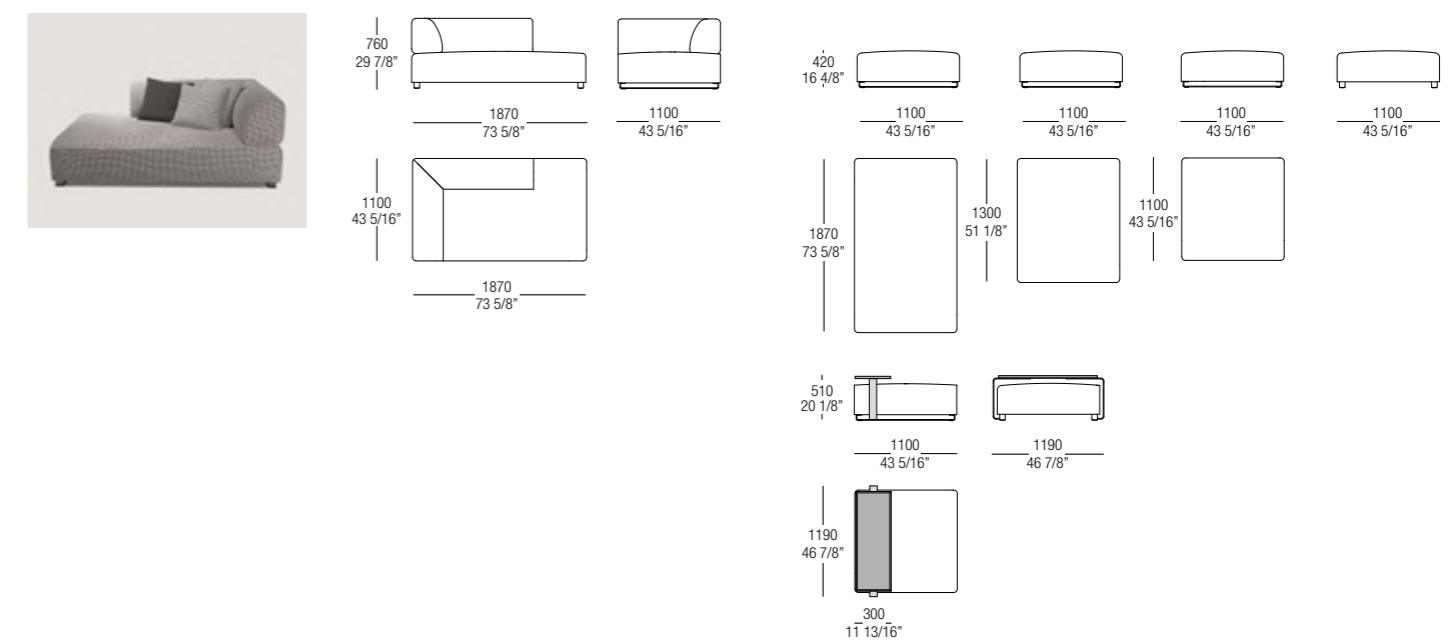
*The cover is available in removable fabric, by expert personnel, or non-removable leather. The top support is available in a matt lacquered finish in all variants.*

**ELEMENTI CENTRALI E TERMINALI \_ CENTRAL AND TERMINAL ELEMENTS**

**CHAISE LONGUE E POUF \_ CHAISE LONGUE AND POUF**



## DIVANETTI SMALL SOFAS

Le forme organiche dei divanetti si integrano con delicatezza nello spazio living, offrendo linee morbide che invitano al relax e alla convivialità. Elementi di design che arredano e accolgono, rivestiti da pregiati tessuti e pelli, completati da strutture metalliche eleganti che ne esaltano il carattere. Un connubio di materiali e forme studiato per creare angoli di comfort e bellezza, dove funzionalità e stile si incontrano in una perfetta armonia compositiva.

*The organic shapes of the sofas blend seamlessly into the living space, offering soft lines that invite relaxation and sociability. Design elements that furnish and welcome, upholstered in fine fabrics and leathers, complemented by elegant metal structures that enhance their character. A combination of materials and forms thoughtfully designed to create corners of comfort and beauty, where functionality and style come together in perfect compositional harmony.*



**Rosè - Chaise Longue**  
Studio 63

---

64



**Virgin**  
Mauro Lipparini

---

72



**Baltimora - Chaise Longue**  
Studio 63

---

80

# ROSE

DESIGN: STUDIO 63

Il divanetto Rosè è contraddistinto da un design organico definito da linee morbide e abbondanti in grado di arredare lo spazio circostante. La sua duttilità permette di soddisfare le esigenze di qualsiasi spazio abitativo, adattandosi sia alla zona giorno che alla zona notte.

*The Rosè sofa is characterized by an organic design defined by soft, abundant lines that furnish the surrounding space. Its versatility allows it to meet the needs of any living environment, adapting seamlessly to both the living and the night area.*







**ROSÈ: DIVANETTO \_ SMALL SOFA**

Il divanetto Rosè è composto da cuscino di seduta in poliuretano espanso sagomato a quote differenziate e ricoperto in fibra di poliestere. Lo schienale in fibra di poliestere è rivestito in fodera di cotone.

Il rivestimento è sfoderabile in tessuto, ecopelle o pelle. È disponibile la variante bicolore con finiture diverse per il rivestimento dello schienale e della seduta.

Il divanetto è dotato di piedini H.40mm. in PVC.

*The Rosè small sofa is composed by a seat cushion made of shaped polyurethane foam with varying densities, covered with polyester fiber. The backrest is made of polyester fiber, covered with a cotton cover.*

*The final cover is available in fabric, eco-leather, or leather; all cover types are removable. A bicolor version is available with different finishes for the backrest and seat upholstery.*

*The small sofa is equipped with 40mm high, in PVC.*

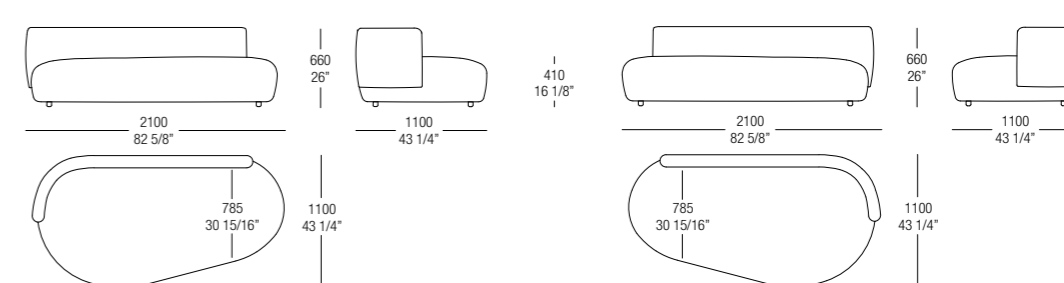
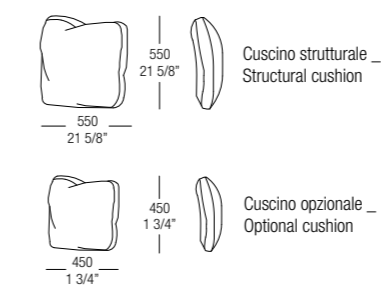
**CHAISE LONGUE****CUSCINI \_ CUSHIONS**

# VIRGIN

DESIGN: MAURO LIPPARINI

Dimensioni compatte, seppur accoglienti, caratterizzano il divano Virgin, un pezzo dalle linee essenziali e ricercate che infondono rigore alla progettualità. Schienale e braccioli, integrati in un unico elemento funzionale e imbottito, avvolgono la seduta profonda che diventa appoggio posteriore modificando l'aspetto estetico e funzionale finale. Una fessura strategicamente collocata tra schienale e seduta alleggerisce il peso volumetrico del sofà.

*Compact but comfortable, the Virgin sofa has essential refined lines that give the design a rigorous tone. The back and armrests merge in a single functional upholstered unit, wrapping the deep seat that becomes the rear support, altering its image and final purpose. A strategic gap between the seat and back lightens the weight of the volume.*









**VIRGIN: DIVANO \_ SOFA**

Il divanetto Virgin è caratterizzato da un elegante e colto recupero di linee morbide anni 50, manifestate nella sezione lenticolare dei braccioli e nella sezione ellittica della base del divanetto. Il contrasto tra esile e massiccio emerge nei piedi filiformi della parte anteriore e nella parte posteriore formata dal prolungamento dello schienale che si trasforma in un corposo e rassicurante appoggio. Il divanetto Virgin è disponibile nella versione lineare o nella versione tonda.

Piedini verniciati metallo opaco nero H. 300 mm.

La seduta è caratterizzata da una scocca in poliuretano schiumato a freddo con rivestimento in tessuto o pelle. È disponibile la variante bicolore con finiture diverse per il rivestimento dello schienale e della seduta. Sfoderabile unicamente la versione in tessuto.

*The Virgin small sofa is characterized by an elegant and refined revival of soft 1950s lines, showcased in the lenticular shape of the armrests and the elliptical section of the sofa's base. The contrast between slender and bulky elements emerges in the front threadlike legs and the rear, where the backrest extends into a solid and reassuring support. The Virgin sofa is available in a linear or round version.*

*The feet are made of matt black varnished metal H.300mm.*

*The seat features a cold-foam polyurethane shell, upholstered in fabric or leather. A bicolor version is available with different finishes for the backrest and seat upholstery. Only the fabric version is removable.*

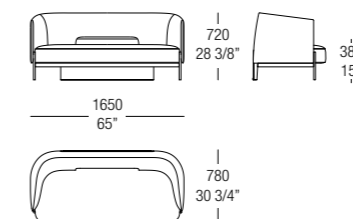
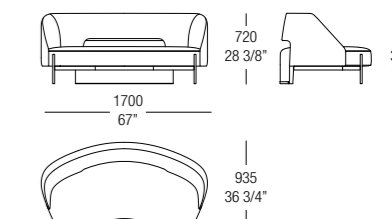
**DIVANO LINEARE \_ LINEAR SOFA****DIVANO TONDO \_ ROUND SOFA**

# BALTIMORA

DESIGN: STUDIO 63

La collezione Baltimora, costituita da poltrona e chaise-longue, è caratterizzata da importanti dimensioni e dall'attenzione sartoriale dell'imbottitura tipica degli anni 70. All'apparenza rigida la struttura tubolare in metallo è vestita da due morbidi imbottiti che accolgono la possibilità di applicare due diverse finiture.

*The Baltimora collection, consisting of an armchair and a chaise-longue, is characterized by significant dimensions and the sartorial attention to upholstery typical of the 1970s.*

*At first glance, the tubular metal structure appears rigid but is adorned with two soft upholsteries that offer the possibility of applying two different finishes.*





**BALTIMORA: CHAISE LONGUE**

La chaise longue Baltimore è caratterizzata dalla struttura in tubolare con sezione ellittica, disponibile in tutte le finiture metallizzate lucide e opache.

La seduta con scocca in acciaio è ricoperta in poliuretano con rivestimento tessuto, ecopelle o pelle. Sfoderabile unicamente la versione in tessuto.

La cuscineria è sostenuta da cinghie ed è formata da due diversi imbottiti che permettono di cambiare la finitura e trasformarsi in bicolore.

*The Baltimore chaise longue is characterized by a metal tubular structure with an elliptical section, available in all glossy and matt metallic finishes.*

*The seat, with a steel shell, is covered in polyurethane and upholstered in fabric, eco-leather or leather. Only the fabric version is removable.*

*The cushioning is supported by webbing and consists of two different padding layers, allowing for a change in finish and the option to create a bicolor look.*

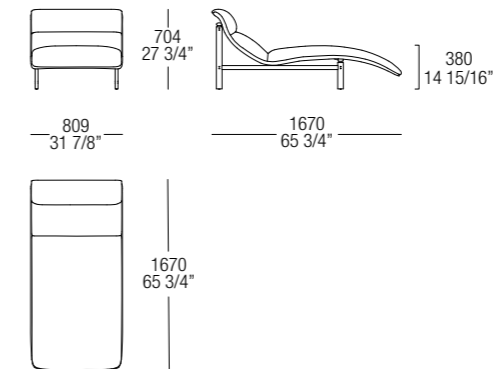
**CHAISE LONGUE**

# POLTRONE ARMCHAIRS

Sagome accoglienti, inni alla convivialità che si prestano a diventare rifugi privati in cui dedicarsi al proprio io. Avvolte da tessuti e pellami ricercati, con dettagli sartoriali che donano un carattere distintivo a ogni poltrona assicurando un look confortevole e sinuoso che spazia dal design più accattivante a quello più discreto.

*Inviting design makes these armchairs equally suitable for socialising or stealing private moments for some quiet time. Covered in the finest fabric and leather, these pieces feature sartorial detailing that gives each armchair a distinctive character, ensuring comfort and cosiness whether the design is extravagant or understated.*



**Monterrey**  
Studio 63

---

88



**Baltimore**  
Studio 63

---

94



**Virgin**  
Mauro Lipparini

---

100



**Ermes**  
Mauro Lipparini

---

108



**Surface**  
Marco Piva

---

116

# MONTERREY

DESIGN: STUDIO 63

La poltrona Monterrey unisce il rigore di una struttura tecnica e metallica, contraddistinta dalla lucentezza del metallo, con una seduta morbida ed accogliente.

L'unione di queste due peculiarità dà vita ad un'eleganza raffinata, perfetta per ogni spazio ed occasione.

*The Monterrey armchair combines the rigor of a technical and metallic structure, characterized by the gleam of metal, with a soft and welcoming seat.*

*The fusion of these two characteristics gives rise to a refined elegance, perfect for any space and occasion.*









---

**MONTERREY: POLTRONA \_ ARMCHAIR**

La poltrona Monterrey è caratterizzata dalla struttura in tubolare con sezione ellittica, disponibile in tutte le finiture metallizzate lucide e opache. L'imbottitura è in poliuretano con rivestimento in tessuto, ecopelle o pelle. Non sfoderabile.

*The Monterrey armchair is characterized by a metal tubular structure with an elliptical section, available in all glossy and matt metallic finishes. The padding is made of polyurethane, with upholstery in fabric, eco-leather or leather. It is non-removable.*

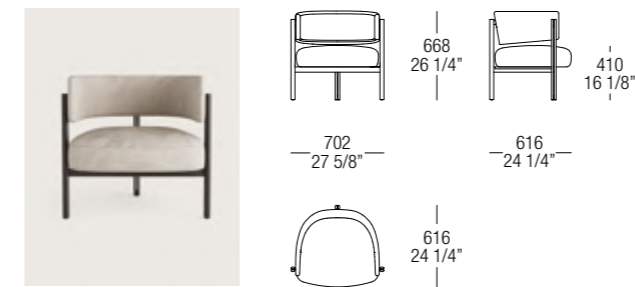
---

**POLTRONA \_ ARMCHAIR**



# BALTIMORA

DESIGN: STUDIO 63

La collezione Baltimora, costituita da poltrona e chaise-longue, è caratterizzata da importanti dimensioni e dall'attenzione sartoriale dell'imbottitura tipica degli anni 70. All'apparenza rigida la struttura tubolare in metallo è rivestita da due morbidi imbottiti che accolgono la possibilità di applicare due diverse finiture.

*The Baltimora collection, consisting of an armchair and a chaise-longue, is characterized by significant dimensions and the tailor-made attention to upholstery typical of the 1970s.*

*At first glance, the tubular metal structure appears rigid but is adorned with two soft upholsteries that offer the possibility to apply two different finishes.*





**BALTIMORA:** POLTRONA \_ ARMCHAIR

La poltrona Monterrey è caratterizzata dalla struttura in tubolare con sezione ellittica in metallo verniciato Canna di Fucile lucido o opaco. L'imbottitura è ricoperta in poliuretano con rivestimento tessuto, ecopelle o pelle. Sfoderabile unicamente la versione in tessuto.

*The Monterrey armchair is characterized by a tubular structure with an elliptical metal section, varnished in glossy or matt Gunmetal. The padding is made of polyurethane and upholstered in fabric, eco-leather or leather. Only the fabric version is removable.*

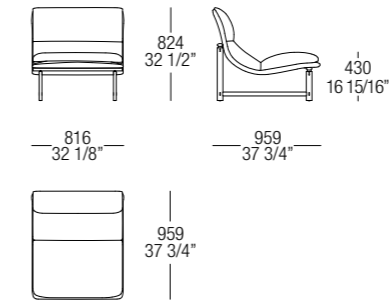
**POLTRONA \_ ARMCHAIR**

# VIRGIN

DESIGN: MAURO LIPPARINI

Dettagli ricercati scandiscono i rigorosi profili della poltroncina Virgin, appartenente all'omonima collezione firmata da Mauro Lipparini. I piedini in metallo conferiscono alla seduta un carattere contemporaneo ed essenziale, in contrasto con le generose imbottiture che invitano al relax. Disponibile in due versioni, con e senza braccioli, accomunate da un fascino estetico equilibrato e architettonico.

*Refined details enhance the rigorous profile of the Virgin armchair, part of the collection of the same name created by Mauro Lipparini. The metal feet give the chair a terse contemporary character, in contrast with the ample padding that invites you to sit back and relax. Available in two versions, with or without armrests, sharing a sense of balanced architectural charm.*









**VIRGIN: POLTRONA \_ ARMCHAIR**

La poltrona Virgin con o senza braccioli è caratterizzata da un elegante e colto recupero di linee morbide anni 50, manifestate nella sezione lenticolare dei braccioli e nella sezione ellittica della base della poltrona. Il contrasto tra esile e massiccio emerge nei piedi filiformi della parte anteriore e nella parte posteriore formata dal prolungamento dello schienale che si trasforma in un corposo e rassicurante appoggio.

I piedini sono verniciati metallo opaco nero. La seduta è caratterizzata da una scocca in poliuretano schiumato a freddo con rivestimento in tessuto o pelle. Non disponibile in ecopelle e velluto. È disponibile la variante bicolore con finiture diverse per il rivestimento dello schienale e della seduta. Sfoderabile unicamente la versione in tessuto.

*The Virgin armchair with or without armrests, it's characterized by an elegant and refined revival of soft 1950s lines, showcased in the lenticular shape of the armrests and the elliptical section of the base. The contrast between slender and bulky elements emerges in the threadlike front legs and the rear, where the backrest extends into a solid and reassuring support.*

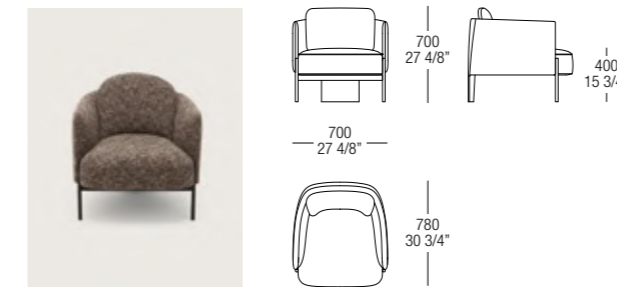
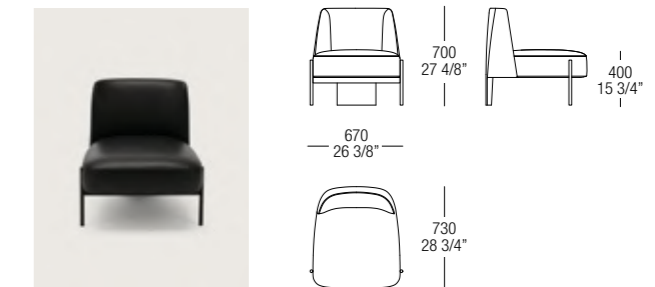
*The feet are made of matt black painted metal. The seat features a cold-foam polyurethane shell, upholstered in fabric or leather. Not available in eco-leather and velvet. A bicolour version is available with different finishes for the backrest and seat upholstery. Only the fabric version is removable.*

**POLTRONA CON BRACCIOLI \_ ARMCHAIRS WITH ARMRESTS**

**POLTRONA SENZA BRACCIOLI \_ ARMCHAIRS WITHOUT ARMRESTS**

# ERMES

DESIGN: MAURO LIPPARINI

Nella poltrona Ermes, la consueta cura artigianale di ogni piccolo dettaglio mette in risalto gli inediti accostamenti, evidenziando le qualità estetiche del prodotto.  
Forme piene creano una dimensione intima, invito al relax.

*The usual craftsmanship for every little detail highlights the unusual combinations of Ermes armchair, emphasizing the aesthetic qualities of the product.  
Full shapes create an intimate dimension, an invitation to relax.*









**ERMES: POLTRONA \_ ARMCHAIR**

Poltrona Ermes con pouf, con scocca in poliuretano schiumato a freddo, è disponibile in due varianti: base fissa in massello di rovere tinto Cenere, Rovere nero, Eucalipto e Tabacco o base girevole in metallo verniciato opaco Canna di Fucile.

Rivestimento in tessuto, ecopelle o pelle, sfoderabile da personale esperto. È disponibile la variante bicolor con finiture diverse per il rivestimento della parte anteriore e del retro.

*Ermes armchair with ottoman, featuring a cold-foam polyurethane shell, is available in two variants: a fixed base made of solid wood in Cenere, Black Oak, Eucalyptus, and Tobacco finishes, or a swivel base in matt Gunmetal varnish.*

*The upholstery is available in fabric, eco-leather or leather, removable by skilled personnel. A bicolor version is available with different finishes for the front and back upholstery.*

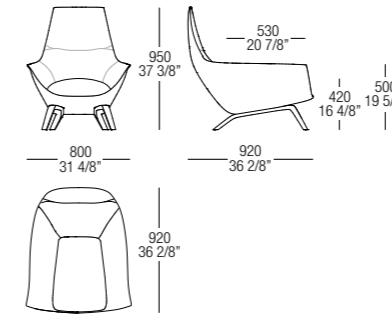
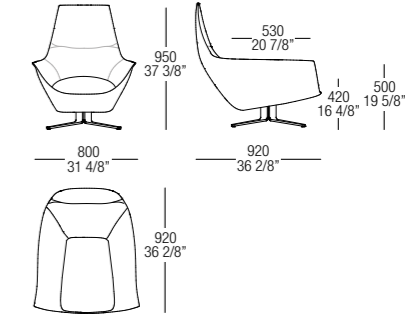
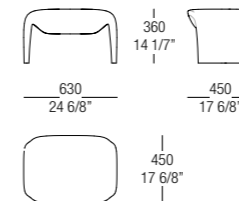
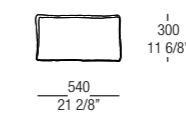
**BASE LEGNO FISSA \_ WOOD FIXED BASE****BASE METALLO GIREVOLE \_ METAL SWIVEL BASE****POUF \_ OTTOMAN****CUSCINO POGGIARENI \_ LOWER BACK SUPPORT CUSHION**

# SURFACE

DESIGN: MARCO PIVA

La raffinata eleganza di Surface nasce dalla sinuosità delle sue linee.  
L'accostamento di colori e materiali differenti definisce il confine tra interno  
ed esterno creando un nido accogliente e soffice.

*The refined elegance of Surface is a result of its sinuous design.  
The combination of colors and different materials defines the boundary between  
inside and outside, creating a comfortable soft nest.*









---

**SURFACE: POLTRONA \_ ARMCHAIR**

La poltrona fissa Surface con scocca in poliuretano schiumato a freddo, rivestimento in tessuto, ecopelle o pelle non sfoderabile. È disponibile la variante bicolore con finiture diverse per il rivestimento della parte anteriore e del retro.

*The fixed Surface armchair with a cold-foam polyurethane shell, upholstered in fabric, eco-leather or leather, non-removable. A bicolor version is available with different finishes for the front and back upholstery.*

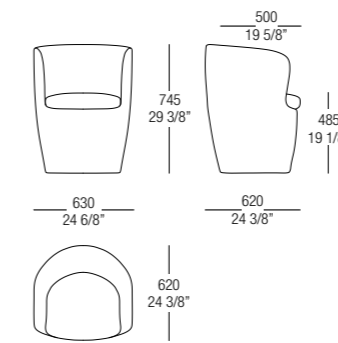
---

**POLTRONA FISSA \_ FIXED ARMCHAIR**

# SEDIE CHAIRS

Un alfabeto di colori e forme, twist di personalità firmate da nomi di spicco del panorama internazionale. Oggetti di uso quotidiano si trasformano in complementi di pregio – da affiancare a importanti tavoli o da far vivere singolarmente – che arricchiscono con armonia l'ambiente portando la propria originalità.

*A kaleidoscope of colour, shape and personality created by the biggest names in the international design industry. These day-to-day objects are transformed into luxury pieces, perfect either for combining with statement tables or leaving on their own, bringing harmony and originality to any space.*



**Monterrey**  
Studio 63

—  
124



**Virgin**  
Mauro Lipparini

—  
130



**Bertha**  
Carlo Marelli e Massimo Molteni

—  
138



**Cleò**  
CR&S MisuraEmme

—  
144



**Naos**  
Mauro Lipparini

—  
152

# MONTERREY

ARMCHAIR

DESIGN: STUDIO 63

La sedia Monterrey unisce il rigore di una struttura tecnica e metallica, contraddistinta dalla lucentezza del metallo, con una seduta morbida ed accogliente.

L'unione di queste due peculiarità dà vita ad un'eleganza raffinata perfetta per ogni spazio ed occasione.

*The Monterrey chair combines the rigor of a technical and metallic structure, characterized by the gleam of the metal, with a soft and welcoming seat. The fusion of these two characteristics gives rise to a refined elegance perfect for any space and occasion.*







**MONTERREY: SEDIA \_ CHAIR**

La sedia Monterrey è caratterizzata dalla struttura in tubolare con sezione ellittica, disponibile in tutte le finiture metallizzate lucide e opache. Lo schienale è in schiumato a freddo con rivestimento in poliuretano mentre la seduta è interamente in poliuretano. Rivestimento in tessuto, ecopelle e pelle, non sfoderabile.

*The Monterrey chair is characterized by a metal tubular structure with an elliptical section, available in all glossy and matt metallic finishes. The backrest is made of cold-foam with a polyurethane coating, while the seat is entirely made of polyurethane. The upholstery is available in fabric, eco-leather, and leather, and it is non-removable.*

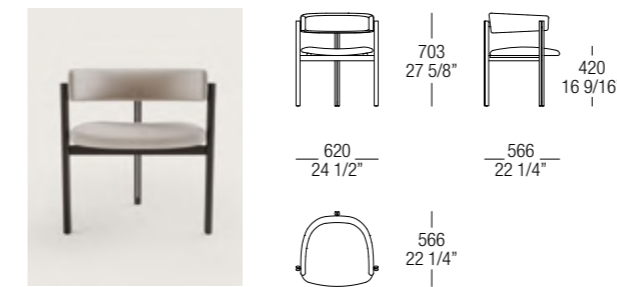
**SEDIA \_ CHAIR**

# VIRGIN

DESIGN: MAURO LIPPARINI

Un raffinato gioco di equilibri contraddistingue la seduta Virgin, firmata dal geniale estro creativo di Mauro Lipparini. Disponibile in due versioni, con e senza braccioli, dotata di un deciso fascino architettonico. L'elemento di sostegno posteriore diventa pilastro d'appoggio a pavimento, imbottito e rivestito, in contrasto con le esili gambe anteriori in metallo. Il taglio contemporaneo delle sedute rievoca le linee morbide degli anni '50.

*A refined game of balances sets the Virgin dining chair apart, thanks to the creative flair of Mauro Lipparini. Available in two versions, with or without armrests, the model relies on striking architectural allure. The rear support becomes a pillar resting on the floor, upholstered and covered, in contrast with the slim frontal metal legs. The contemporary tone suggests the soft lines of the Fifties.*







**VIRGIN: SEDIA \_ CHAIR**

Sedia Virgin con o senza braccioli, caratterizzata da un elegante e colto recupero di linee morbide anni 50, manifestate nella sezione lenticolare dei braccioli e nella sezione ellittica del sostegno posteriore.

Il contrasto tra esile e massiccio emerge nei piedi filiformi della parte anteriore e nella parte posteriore formata dal prolungamento dello schienale che si trasforma in un corposo e rassicurante appoggio.

La seduta è caratterizzata da una scocca in poliuretano schiumato a freddo con rivestimento in tessuto o pelle, non disponibile in ecopelle o in velluto, sfoderabile unicamente la versione in tessuto. È disponibile la variante bicolore con finiture diverse per il rivestimento dello schienale e della seduta.

*Virgin chair with or without armrests, characterized by an elegant and cultured reinterpretation of soft 1950s lines, manifested in the lenticular section of the armrests and the elliptical section of the rear support.*

*The contrast between slender and bulky elements is highlighted by the threadlike front legs and the back section, where the backrest extends into a solid and reassuring support.*

*The seat is defined by a cold-foam polyurethane shell with upholstery in fabric or leather, not available in eco-leather or velvet, and the fabric version is removable. A bicolour variant is available, with different finishes for the backrest and seat upholstery.*

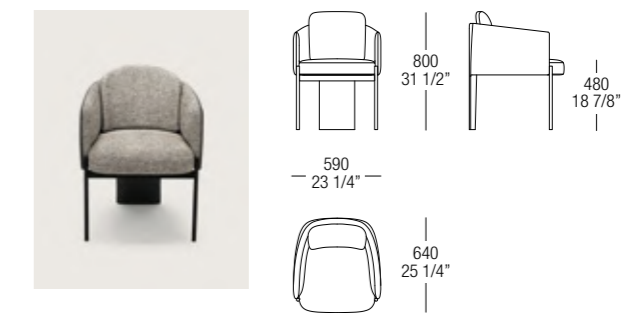
**SEDA SENZA BRACCIOLI \_ CHAIR WITHOUT ARMRESTS****SEDA CON BRACCIOLI \_ CHAIR WITH ARMRESTS**

# BERTHA

DESIGN: CARLO MARELLI E MASSIMO MOLTENI

Connubio di sinuosità e finezza, la seduta Bertha, disponibile nella versione senza braccioli, stuzzica il gusto con la sua struttura in massello di frassino tinto nero. Un progetto che coniuga principi estetici ed ergonomici.

*All curved lines and finesse, Bertha is available without armrests. Its solid wood structure in black painted finish is effortlessly stylish, for a design that combines both aesthetics and ergonomics.*







**BERTHA:** SEDIA \_ CHAIR

La sedia Bertha ha una struttura lineare in legno caratterizzata da una lavorazione artigianale in massello di frassino tinto Tabacco o Rovere nero con schienale curvato anatomico. Seduta imbottita e rivestita tessuto, ecopelle o pelle. Rivestimento sfoderabile da personale esperto.

*Bertha chair with linear wooden structure crafted with artisanal expertise in solid wood, stained Tobacco or black oak, featuring a curved anatomical backrest. The padded seat is upholstered in fabric, eco-leather or leather, with the upholstery removable by a skilled professional.*

## SEDIA \_ CHAIR



# CLEÒ

DESIGN: CR&S MISURAEMME

Espressione altissima di un gusto raffinato che integra lo stile classico a un mood contemporaneo, la sedia Cleò coniuga l'estrema linearità della base in massello al disegno morbido dello schienale imbottito. L'elegante lavorazione artigianale dà mostra di sé nella perfezione delle cuciture che valorizzano la seduta e richiamano tradizioni lontane.

*Sublime expression of a refined taste that integrates classic style with a contemporary mood, the Cleò chair combines the extreme linearity of the solid wood base with the soft design of the padded backrest. The elegant craftsmanship is revealed in the perfection of the seams that enhance the seat and evoke old traditions.*







**CLEO: SEDIA \_ CHAIR**

Collezione di sedie Cleo è composta da 4 differenti tipologie: schienale basso con e senza braccioli, schienale alto e sgabello.

La base è caratterizzata da una lavorazione artigianale in massello di rovere tinto disponibile in Cenere, Rovere nero, Olmo Grey, Eucalipto e Tabacco. La seduta e lo schienale sono in curvato imbottito con rivestimento disponibile in tessuto, ecopelle o pelle, sfoderabile da personale esperto.

*Cleo chairs collection consisting of four different types: low backrest with or without armrests, high backrest, and stool.*

*The base is crafted with artisanal expertise in solid oak, available in Cenere, Black Oak, Grey Elm, Eucalyptus, and Tobacco finishes. The seat and backrest are padded and made of curved wood, with upholstery available in fabric, eco-leather or leather, removable by a skilled professional.*

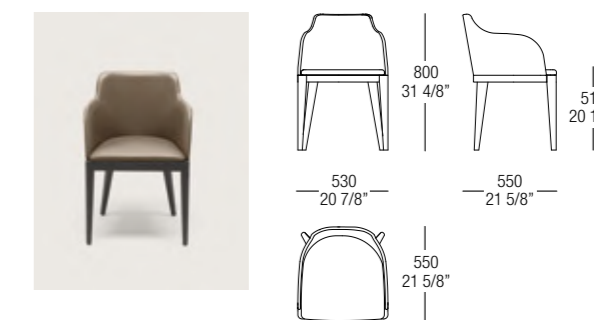
**SCHIENALE BASSO \_ LOW BACKREST****SCHIENALE BASSO CON BRACCIOLI \_ LOW BACKREST WITH ARMREST****SCHIENALE ALTO \_ HIGH BACKREST****SGABELLO \_ STOOL**

# NAOS

DESIGN: MAURO LIPPARINI

Sintesi di versatilità e comfort, la poltroncina Naos si reinventa con una base in legno massello. Le forme della seduta suggeriscono un profilo armonioso e rivelano l'attenzione per gli elementi progettuali e compositivi che ne fanno una proposta di alto valore estetico.

*A synthesis of versatility and comfort, the Naos chair is reinvented with a solid wood base. The precious design of the seat suggests a harmonious profile and reveals great attention to the design and compositional elements that make it a highly aesthetic piece of furniture.*







---

**NAOS: SEDIA \_ CHAIR**

La sedia Naos è caratterizzata da una lavorazione artigianale della base in massello di rovere tinto disponibile in Cenere, Rovere nero, Olmo Grey, Eucalipto e Tabacco.

La seduta e lo schienale sono in poliuretano schiumato a freddo, rivestiti in tessuto e pelle, sfoderabile da personale esperto. È disponibile la variante bicolore con finiture diverse per il rivestimento dello schienale e della seduta.

*The Naos chair is distinguished by the artisanal craftsmanship of its solid oak base, available in Cenere, Black Oak, Grey Elm, Eucalyptus, and Tobacco finishes.*

*The seat and backrest are made of cold-foam polyurethane, upholstered in fabric or leather, and removable by a skilled professional. A bicolour variant is available, offering different finishes for the backrest and seat upholstery.*

---

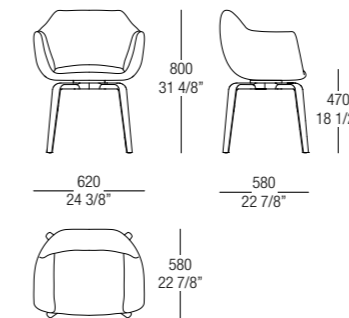
**BASE LEGNO FISSA \_ WOOD FIXED BASE**



# TAVOLI

## TABLES

Presenze sceniche importanti ed elementi d'arredo, sono gli indiscussi protagonisti della zona living. Dalle linee rigorose o arrotondate, diversi per dimensioni e forma, ma accomunati dall'elevata qualità dei materiali prescelti e dall'attenzione ai dettagli, caratteristiche alla base del DNA aziendale.

*The undisputed protagonists of the living room, tables are an imposing presence in any space. Whether linear or curved, tables can have different dimensions and shapes yet all feature the best materials and unparalleled attention to detail – qualities synonymous with the company DNA.*



**Ala**  
Ferruccio Laviani

—  
160



**Gaudì**  
Ferruccio Laviani

—  
178



**Janus Lounge**  
Francesco Lucchese

—  
188

# ALA

DESIGN: FERRUCCIO LAVIANI

Scaturito dall'incontro tra creatività e sapienza artigianale, il tavolo Ala conquista la zona giorno diventandone l'attore principale attorno al quale inscenare la comédie humaine del vivere quotidiano. Il piano tondo o semiovale, definito da un bordo che ne assottiglia la percezione dello spessore, appare sospeso nello spazio e pronto a spiccare il volo grazie alle gambe affusolate, dalle fattezze di un'ala di aeroplano che ne hanno ispirato il nome.

*A combination of creativity and expert craftsmanship, the Ala table is the dominant presence in the living room – the setting for the day-to-day goings-on of domestic life. The round or semi-oval table top, outlined by a border that takes the edge off the thickness, appears suspended in mid-air, almost ready to take flight. The tapered legs only high lighten this effect, based on the design of the wings of an aeroplane.*









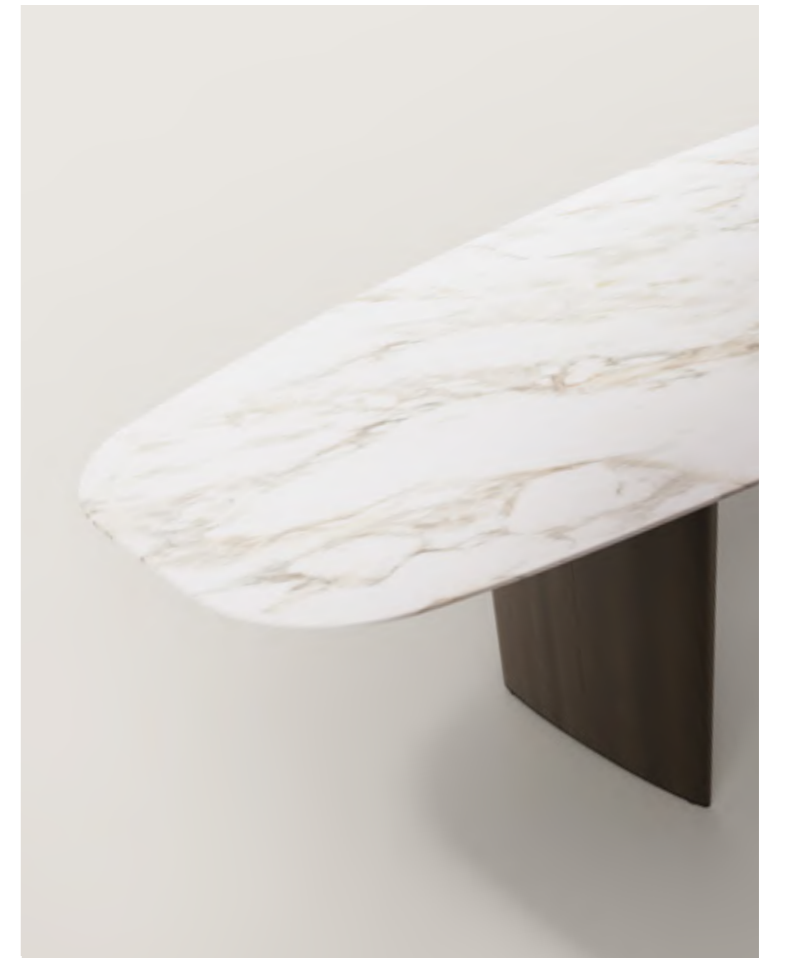

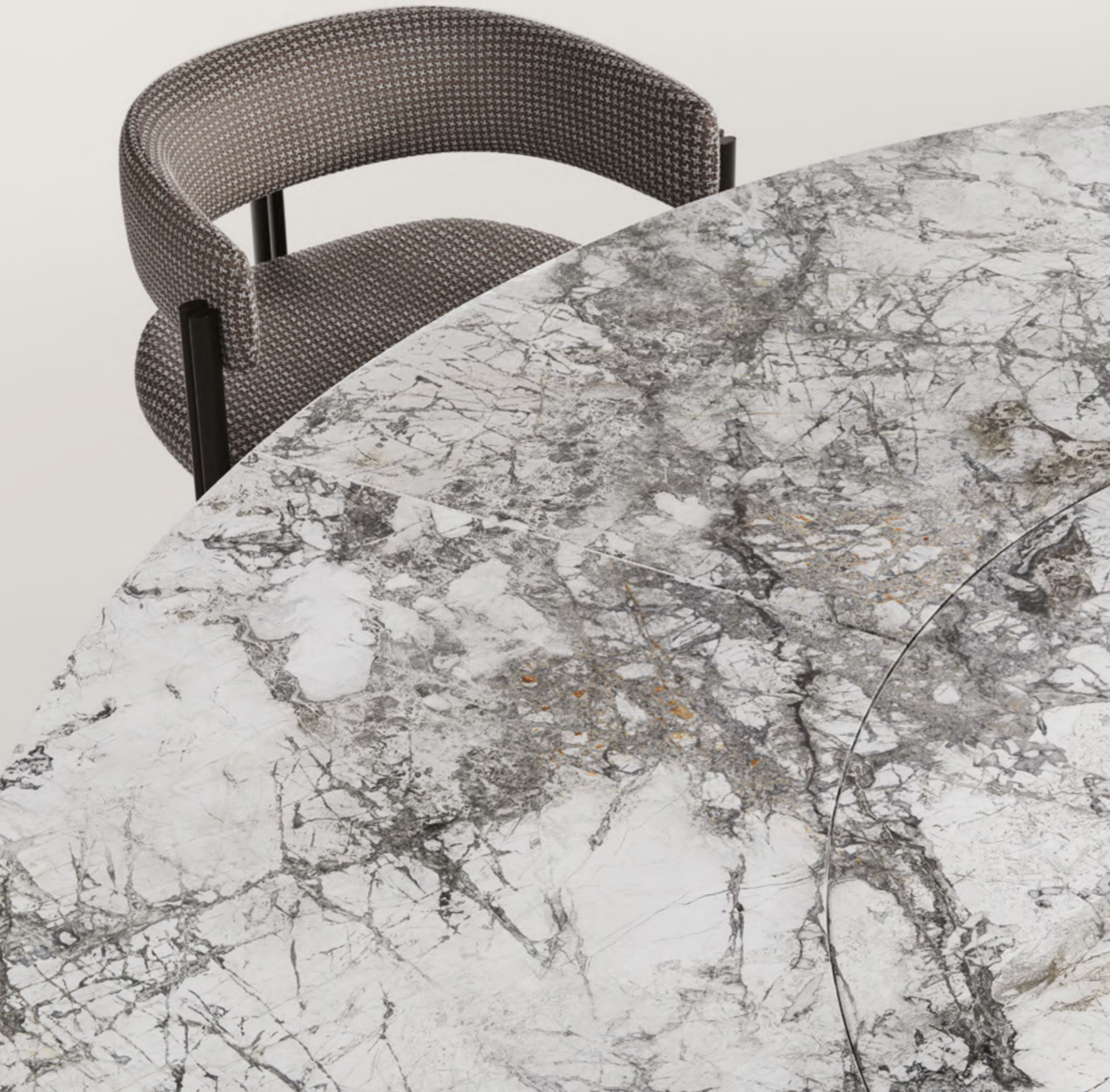





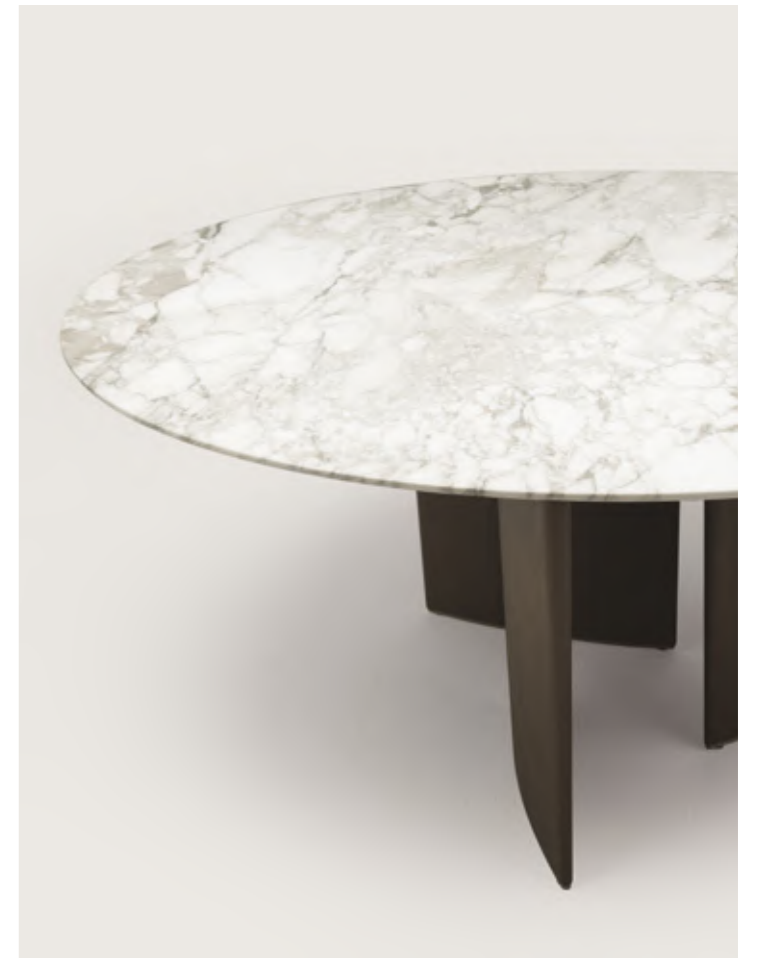

ALA: TAVOLO \_ TABLE

Collezione di tavoli Ala disponibili in due varianti: semiovale o tondo definiti da un bordo che ne assottiglia lo spessore. La finitura in vetro è caratterizzata dalla bisellatura del piano.

Il piano semiovale è disponibile in essenza, in marmo sp. 20 mm in tutte le varianti, in vetro trasparente naturale sp. 15 mm, in vetro trasparente fumè sp. 12 mm e in vetro mandarino sp. 16 mm unicamente per la dimensione L. 3100 mm.

Il piano circolare è disponibile in marmo sp. 20 mm tutte le varianti e in essenza tutte le varianti. Per le versioni in marmo è presente il sottopiano in laccato opaco Sepia. Per il piano rotondo è prevista l'aggiunta del vassoio girevole Lazy Susan sul piano centrale, disponibile in finiture legno, marmo in tutte le varianti o laccato opaco e anticato. Il Lazy Susan è sporgente per le dimensioni di piano Ø 1550 e 1650 mm e incassato nelle dimensioni di piano Ø 1800, 2000, 2200 e 2400 mm.

Le gambe del tavolo possono essere in essenza Rovere nero, Eucalipto e Tabacco, laccate opache, laccate anticato o laccate lucide Canna di Fucile.

*Ala tables collection available in two variants: semi-oval or round, characterized by edges that taper in thickness. The glass finish features a beveled top.*

*Semi-oval top is available in wood veneer th. 35 mm, marble in all variants th. 20mm, natural transparent glass th 15mm, fumè transparent glass th. 12mm and Mandarin glass th. 16mm (exclusively for the 3100 mm length).*

*Circular top is available in marble in all variants th. 20mm. and wood veneer in all variants th.35mm. For marble versions, the table includes an underlay in matt Sepia lacquer. The round top also features the option of a Lazy Susan, a rotating tray placed at the center of the table, available in wood, marble all variants, or matt and antiqued lacquer finishes. The Lazy Susan is projected for top sizes of Ø 1550 and 1650 mm and recessed in top sizes of Ø 1800, 2000, 2200 and 2400 mm.*

*The table legs can be customized in the following finishes: Black Oak, Eucalyptus, or Tobacco veneers, painted matt lacquer, antiqued lacquer, or glossy Gunmetal lacquer.*

TAVOLO SEMIOVALE \_ SEMIOVAL TABLE

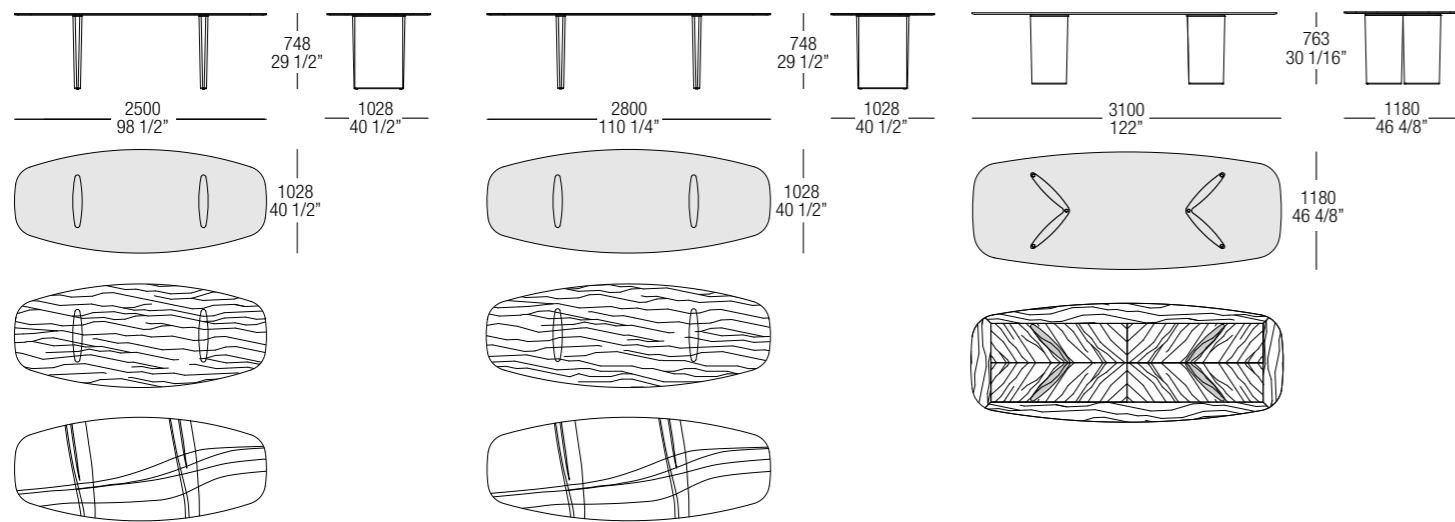

TAVOLO TONDO \_ ROUND TABLE

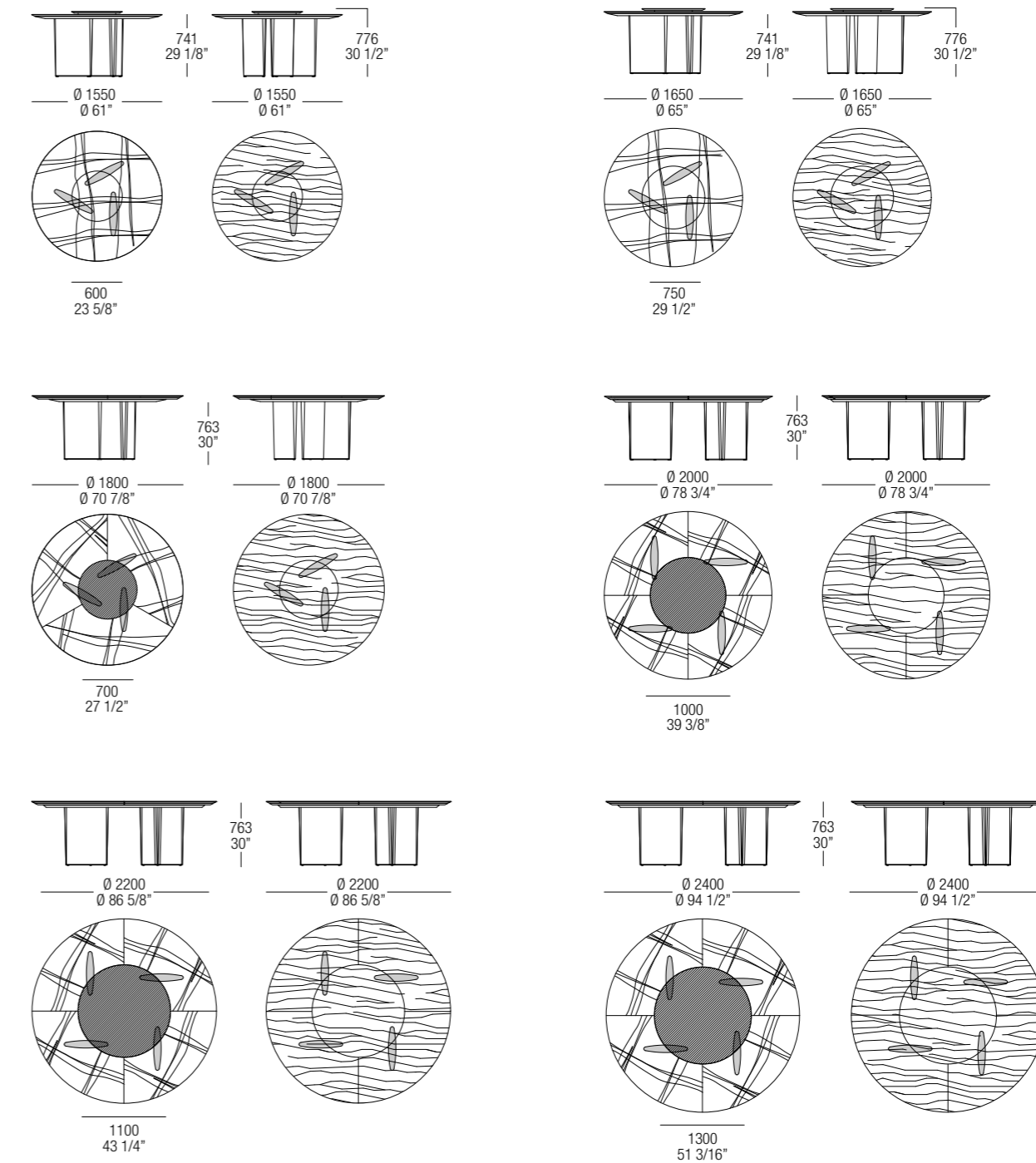

# GAUDÌ

DESIGN: FERRUCCIO LAVIANI

Preziosità materiche e design funzionale per uno stile senza tempo.  
Con tali cifre stilistiche Gaudì regala effetti inaspettati, grazie al piano sagomato semiovale impreziosito dalla presenza di pietre naturali d'eccellenza, essenze o marmo, rispondendo alle singole esigenze d'arredo.

*Stunning materials and practical design come together for timeless style.  
Gaudì packs an unexpected punch thanks to its tapered semi-oval top, embellished with either gorgeous natural stone, wood or marble, depending on individual furnishing needs.*





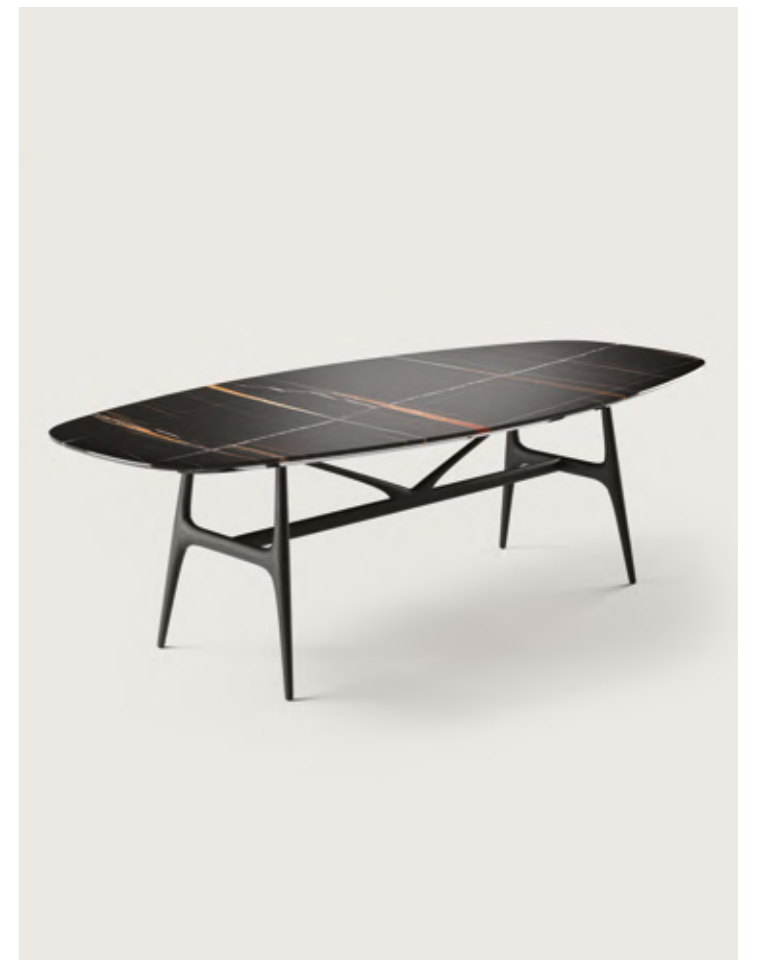





## GAUDÌ: TAVOLO \_ TABLE

Serie di tavoli Gaudì caratterizzati da un design senza tempo. Base in massello di Rovere tinto disponibile in essenza Cenere, Rovere nero, Eucalipto e Tabacco e piano semiovale sagomato disponibile in marmo sp. 20 mm tutte le varianti ed essenza sp. 30 mm Cenere, Rovere nero, Eucalipto e Tabacco.

*Gaudì is a series of tables characterized by a timeless design. The base is crafted in solid stained oak, available in Cenere, Black Oak, Eucalyptus, and Tobacco finishes. The shaped semi-oval top is available in marble in all variants th. 20mm, or wood veneer in Cenere, Black Oak, Eucalyptus, and Tobacco finishes th.30mm.*

## TAVOLO FISSO \_ FIXED TABLES

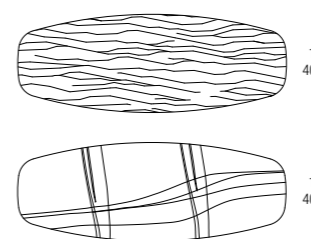
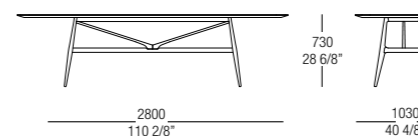
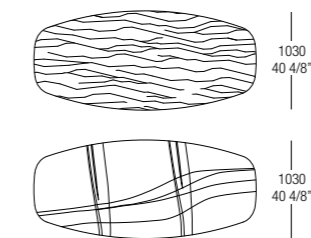
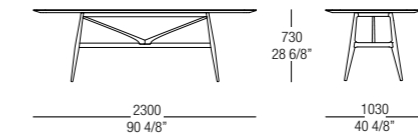

# JANUS LOUNGE

DESIGN: FRANCESCO LUCCHESI

La collezione Janus si arricchisce di un nuovo tavolo con piano rotondo sorretto dalla peculiare e caratteristica struttura ottenuta dall'accostamento di due doppie "C" realizzate in metallo.

La purezza stilistica, unita ad una grande funzionalità, conferisce al tavolo Janus un carattere versatile e rigoroso, ideale per angoli relax distesi e conviviali.

*The Janus collection now includes a new table with a round top supported by a uniquely characteristic structure made by juxtaposing two double C-shaped metal parts.*

*The stylistic purity combined with great functional performance, makes the Janus a versatile, elegant solution, ideal for convivial zones and total relaxation.*





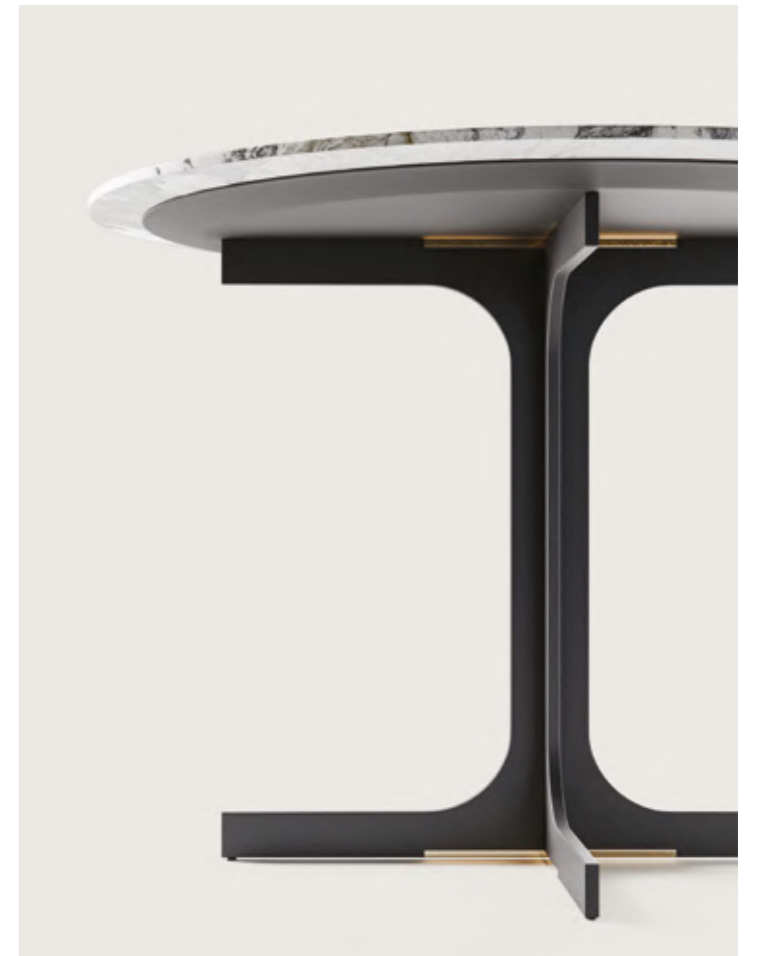





---

**JANUS LOUNGE: TAVOLO \_ TABLE**

Janus è un tavolo con struttura caratterizzata da un accoppiamento di due doppie "C" in metallo, in modo da formare una croce, in finitura nichelata oro. Il piano è disponibile in essenza lucida e opaca sp. 22 mm in Rovere nero, Olmo Grey, Eucalipto, Ebano e Tabacco e marmo sp. 20 mm in tutte le varianti.

*Janus is a table with a structure featuring two paired "C" shapes in metal, arranged to form a cross, with a gold nickel-plated finish. The top is available in glossy or matt wood veneer in Black Oak, Grey Elm, Eucalyptus, Ebony, and Tobacco finishes th.22 mm or Marble in all variants th.20 mm.*

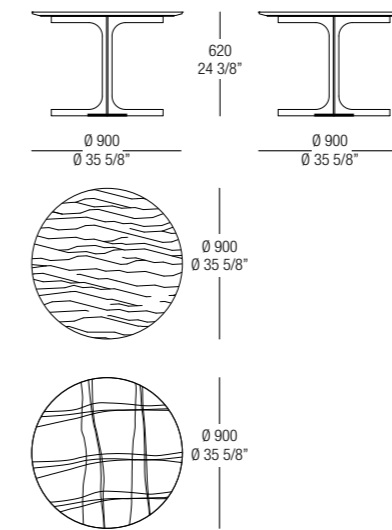
---

**TAVOLO TONDO \_ ROUND TABLES**

# CONSOLLE E SCRITTOI *CONSOLES AND WRITING DESKS*

Presenze discrete nell'abitare contemporaneo: sobrie, ma di carattere.  
Dalle linee rigorose o arrotondate, diverse per dimensioni e forme,  
ma accomunate dall'elevata qualità dei materiali prescelti  
e dall'attenzione ai dettagli, caratteristiche alla base del DNA aziendale.

*Console and writing desks supply that extra something in the  
contemporary living panorama: sober yet characterful. Whether linear  
or curved, tables can have different dimensions and shapes yet all feature  
the best materials and unparalleled attention to detail –  
qualities synonymous with the company's DNA.*



**Janus**  
Francesco Lucchese

—  
196



**Eros**  
Studio 63

—  
200

# JANUS

DESIGN: FRANCESCO LUCCHESI

Una consolle moderna, dalla personalità spiccata, Janus accorda l'intento pratico e l'indole decorativa per realizzare un arredo dalle molteplici destinazioni d'uso. La silhouette slanciata gioca con i contrasti tra la struttura in metallo e il piano, disponibile in diverse alternative materiche e di configurazione.

*A modern console with a forceful personality, Janus combines practicality and decorative flair in a piece that lends itself to many different uses. The slender silhouette plays with the contrast between the metal structure and the top, available in a range of materials and configurations.*



**JANUS:** CONSOLLE \_ CONSOLE

Janus è una consolle con struttura caratterizzata da un accoppiamento di due doppie "C" in metallo, in modo da formare una croce, in finitura metallo verniciato nero con crociera nichelata oro. Il piano è disponibile in essenza lucida e opaca sp. 22 mm Rovere nero, Olmo Grey, Eucalipto, Ebano e Tabacco e in marmo sp. 20 mm in tutte le varianti.

*Janus is a console table with a structure characterized by two paired "C" shapes in metal, arranged to form a cross, finished in black-painted metal with a gold nickel-plated crosspiece. The top is available in glossy or matt wood veneer th.22 mm. in Black Oak, Grey Elm, Eucalyptus, Ebony, and Tobacco finishes, as well as in marble th. 20 mm. in all variants.*

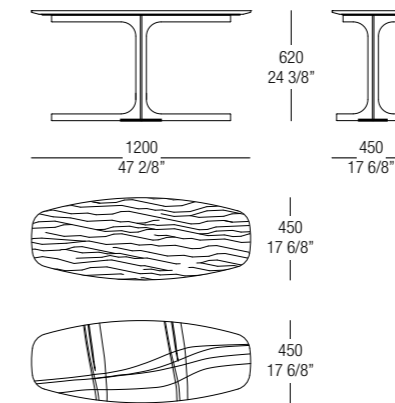
**CONSOLLE SEMIOVALE \_ SEMI-OVAL CONSOLE**

# EROS

DESIGN: STUDIO 63

Lo scrittoio Eros si contraddistingue per il design leggero e raffinato e per la qualità dei materiali. La struttura essenziale metallizzata, rende il contenitore e il top quasi sospesi. Il gioco visivo creato dal dialogo fra i diversi materiali introduce nelle zone della casa un elemento di inconfondibile gusto e artigianalità.

*The Eros writing desk stands out for its light and refined design and the quality of the materials. The minimal structure in varnished metal, makes the container and the top almost suspended. The visual play created by the dialogue between the different materials introduces an element of unmistakable taste and craftsmanship into the home.*







---

**EROS: SCRITTOIO \_ WRITING DESK**

Lo scrittoio Eros si contraddistingue per il sofisticato dialogo tra i diversi materiali che lo compongono: metallo, marmo, legno. La struttura di diametro ovale metallico, disponibile verniciata in tutte le finiture metallizzate lucide e opache, sostiene i cassetti in essenza Rovere nero e un pregiato piano di appoggio disponibile in essenza opaca Rovere nero sp. 20 mm, o in tutte le varietà del marmo sp. 20 mm.

Il meccanismo di apertura è a completa scomparsa e l'interno dei cassetti è in melaminico Primo Fiore. Il piano è caratterizzato da una sofisticata rientranza all'interno della quale è inserita la struttura in metallo.

*The Eros writing desk is distinguished by the sophisticated dialogue between the various materials that compose it: metal, marble, and wood. The oval metal structure, available in all glossy and matt metallic finishes, supports drawers in Black Oak veneer and a refined top, available in matt Black Oak th. 20 mm, or all marble variants th. 20 mm.*

*The opening mechanism is fully concealed, and the interior of the drawers is lined with Primo Fiore melamine. The top features a sophisticated recess into which the metal structure is integrated.*

---

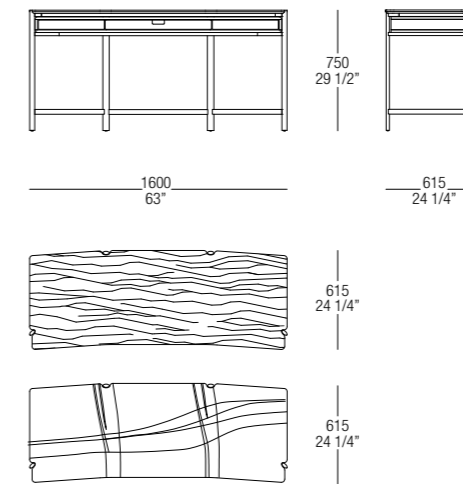
**SCRITTOIO \_ WRITING DESK**



# TAVOLINI SMALL TABLES

Tocchi leggeri nell'abitare contemporaneo: delicati, ma di carattere, portavoce di un linguaggio estetico che rappresenta un connubio perfetto tra design contemporaneo, funzionalità e materiali preziosi. Molteplici le sfaccettature, le dimensioni e le finiture per un raffinato alternarsi di ritmi e combinazioni.

*Small tables supply that extra something in the contemporary living panorama: delicate yet characterful, they represent the perfect fusion of contemporary design, practicality and the finest materials. They come in all designs, shapes and finishes to open the door for an array of different feels and combinations.*



**Seattle**  
Studio 63  
—  
208



**Stowe**  
Studio 63  
—  
214



**Boston**  
Studio 63  
—  
220



**Gemini**  
Andrei Munteanu  
—  
224



**Stiletto**  
Andrei Munteanu  
—  
230



**Janus**  
Francesco Lucchese  
—  
236



**Sirius**  
Andrei Munteanu  
—  
242



**Rialto**  
CR&S MisuraEmme  
—  
248



**Moai**  
Riccardo Gussoni  
—  
254

# SEATTLE

DESIGN: STUDIO 63

Dall'ispirazione al mondo organico nasce il trittico Seattle. La memoria di una terra arida, espressa attraverso la verniciatura materica sul legno di massello. Un'artigianale e raffinata struttura, simbolo della lavorazione Made in Italy, decorata da moderne smaltature.

*Inspired by the organic world, the Seattle triptych was born. It evokes the memory of a barren land, expressed through a textured finish on solid wood. A handcrafted and refined structure, symbolizing Italian craftsmanship, decorated with modern enamel coatings.*





**SEATTLE:** TAVOLINO \_ SMALL TABLE

Serie di tavolini Seattle in legno di massello accoppiato, disponibili con finitura laccata metallizzata o in una materia laccatura ramata realizzata con una tecnica sviluppata dal Centro Ricerca e Sviluppo CR&S interno all'azienda.

*Seattle small tables series made of solid wood, available with metallic lacquered finish or in a copper lacquer material crafted using a technique developed by the CR&S Research and Development Center within the company.*

## TAVOLINO \_ SMALL TABLE

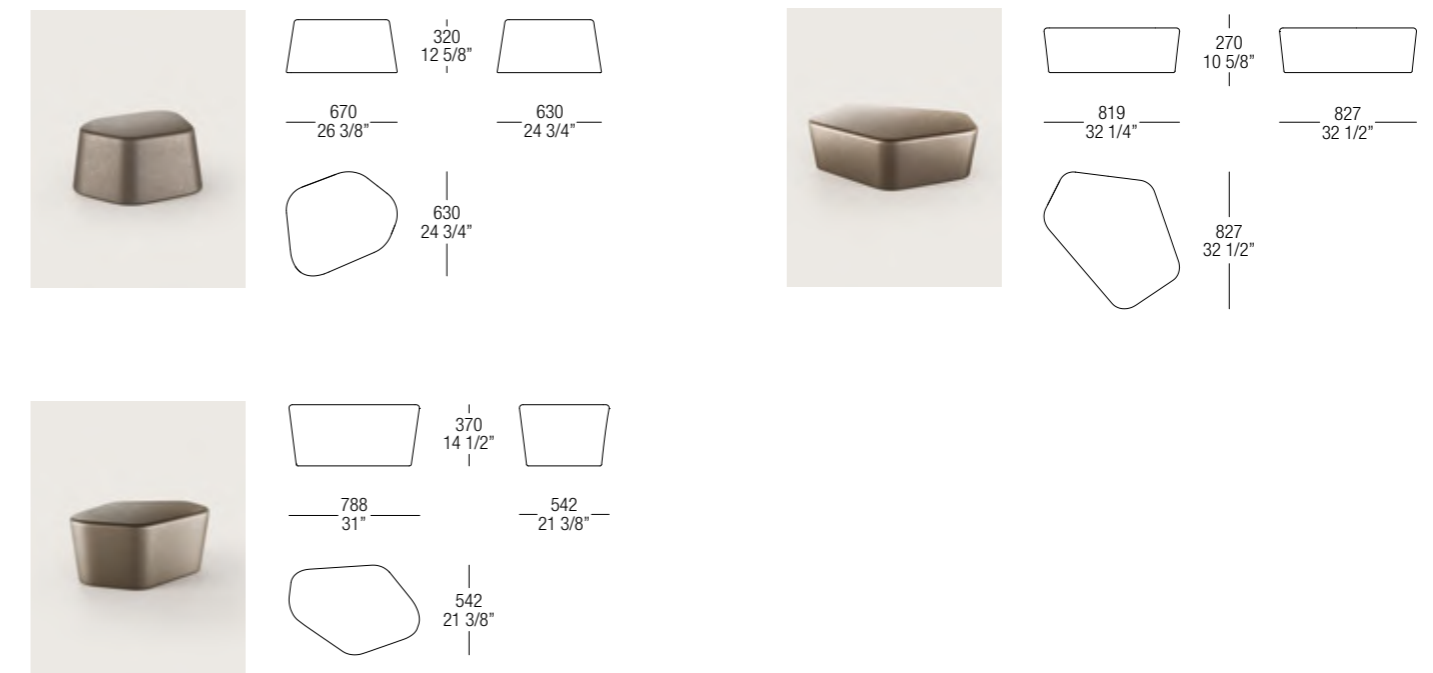

# STOWE

DESIGN: STUDIO 63

La natura e la sua limpidezza sono state le fonti di ispirazione di Stowe.  
 Da una parte levigato e raffinato, dall'altra materico e irregolare,  
 la bellezza del vetro colato è la memoria dell'increspatura del mare.  
 Il tavolino Stowe rappresenta l'essenza del Made in Italy, che grazie  
 alla sua lavorazione artigianale, aggiunge un tocco di raffinatezza nella zona living.

*Nature and its clarity were the sources of inspiration for Stowe. On one side,  
 smooth and refined; on the other, material and irregular, the beauty of cast glass evokes  
 the memory of the sea's ripples. The Stowe small table embodies the essence of Made in Italy,  
 adding a touch of sophistication to the living area through its artisanal craftsmanship.*

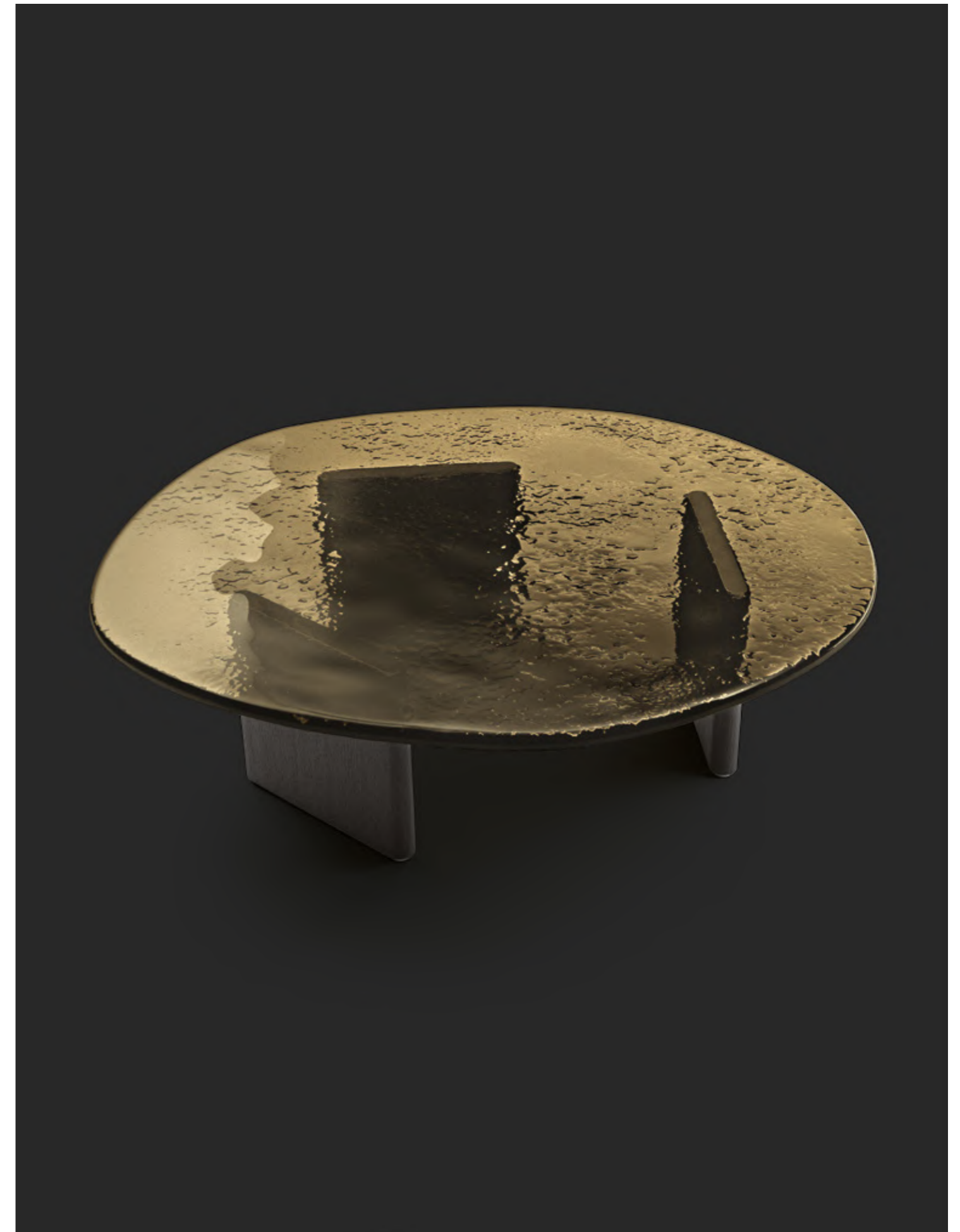







---

**STOWE: TAVOLINO \_ SMALL TABLE**

Serie di tavolini Stowe caratterizzati da forme semiovali irregolari e contraddistinti dal piano in vetro colato bronzo, posizionato con la parte liscia rivolta verso l'alto, sorretto dalle gambe in legno curvato di Rovere Nero tramite piastre in acciaio inox.

*Series of Stowe small tables with irregular semioval shapes distinguished by the bronze casted glass top, positioned with the smooth part facing upwards, supported by the curved legs in Black Oak through stainless steel plates.*

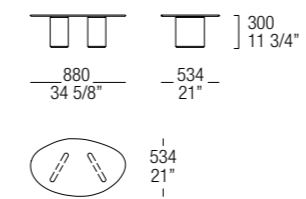
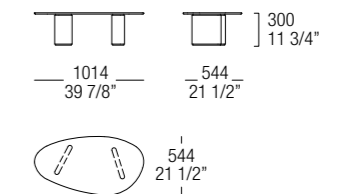
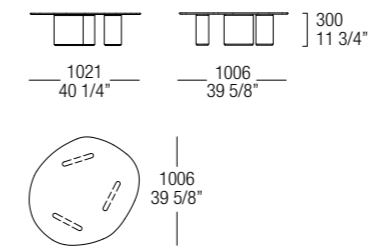
---

**TAVOLINO \_ SMALL TABLE**

# BOSTON

DESIGN: STUDIO 63

Un complemento solido e organico, una forma compatta con una forte componente tattile.

Un complemento unico e secolare che prende vita da un'ispirazione naturale, una memoria lontana. I granelli di sabbia, reminiscenza del nostro ecosistema, rivestono la cilindrica forma del massello donando un effetto autentico che evoca la profonda conoscenza della lavorazione del legno.

*A solid and organic piece, a compact shape with a strong tactile component.*

*A unique and timeless accessory brought to life by natural inspiration, a distant memory.*

*The grains of sand, a reminiscence of our ecosystem, coat the cylindrical shape of the solid wood, creating an authentic effect that evokes a deep knowledge of woodworking craftsmanship.*









---

**BOSTON:** TAVOLINO \_ SMALL TABLE

Il tavolino Boston è in massello di legno accoppiato rivestito da una speciale sabbiatura in effetto cemento chiaro con dei granuli più scuri che si mischiano con un fondo uniforme. Il piano d'appoggio è in vetro verniciato Nero.

*The Boston small table is in solid coupled wood coated with a special sandblasting in light cement effect with darker granules that mix with the bottom uniform. The top is in black painted glass.*

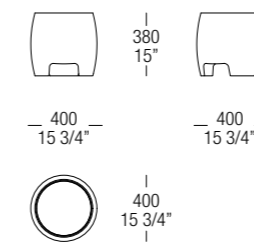
---

TAVOLINO \_ SMALL TABLE

# GEMINI

DESIGN: ANDREI MUNTEANU

Linee geometriche pulite ed essenziali contrassegnano la collezione Gemini, declinata in due coffee table dai profili netti e i volumi generosi. La matericità del legno dialoga con una brillante finitura per aggiungere valore ai complementi, concepiti per arredare con eleganza spazi domestici e non.

*Clean and essential geometric lines for the Gemini collection, including two coffee tables with striking profiles and ample volumes. The material substance of wood establishes a dialogue with the finish to add appeal to the pieces, conceived to elegantly furnish spaces in the home or elsewhere.*





**GEMINI: TAVOLINO \_ SMALL TABLE**

La collezione di tavolini Gemini è composta da due versioni, una con forma quadrata e una rotonda con un'altezza del piano h. 160 mm. Realizzati in folding e impiallacciati nelle finiture opache e lucide: Rovere nero, Olmo Grey ed Ebano. La peculiarità del piano è data dall'accostamento secondo un disegno appositamente studiato dell'impiallacciatura valorizzandone l'aspetto. I piedini sono in metallo verniciato opaco Canna di Fucile.

*Collection of Gemini small tables with square and round shapes, featuring a tabletop h. 160 mm. The top is made using a folding technique and veneered in the following matt and glossy finishes: Black Oak, Grey Elm, and Ebony. The distinctiveness of the tabletop lies in the arrangement of the veneer, specifically designed to enhance its appearance. The feet are made of matt Gunmetal-painted metal.*

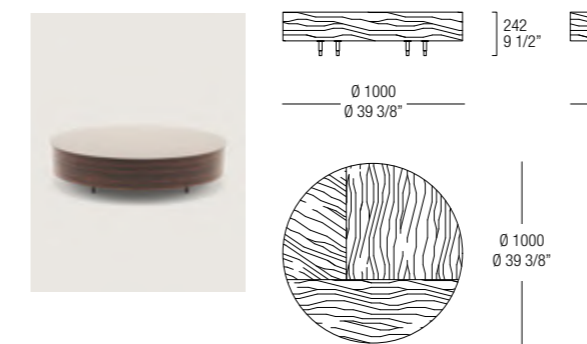
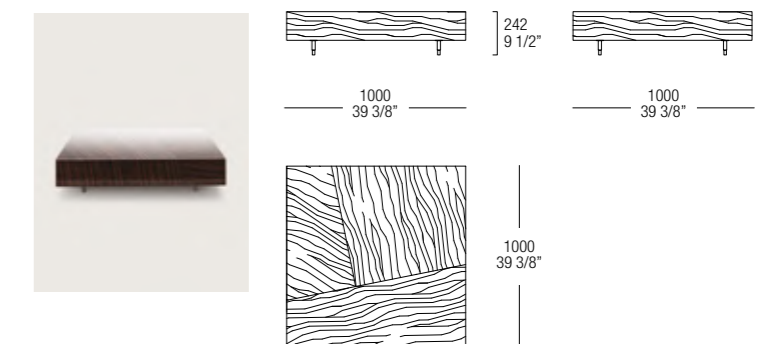
**TAVOLINO TONDO \_ ROUND SMALL TABLE****TAVOLINO QUADRATO \_ SQUARE SMALL TABLE**

# STILETTO

DESIGN: ANDREI MUNTEANU

Sono i contrasti materici a sottolineare l'identità risoluta della famiglia di complementi Stiletto. Marmo, metallo e legno si alternano in proposte dagli effetti geometrici netti che ne esaltano la struttura slanciata. Gli spessori importanti e il variare della combinazione delle finiture creano un elegante gioco di colori.

*Material contrasts underline the forceful identity of the Stiletto family of furnishing complements. Marble, metal and wood alternate in creations with vivid geometric effects that enhance its slender structure. Its important thicknesses and the combination of different finishings provide an elegant mix of colours.*





**STILETTO: TAVOLINO \_ SMALL TABLE**

Serie di tavolini Stiletto con differenti altezze e dimensioni di diametro, composti da uno "stilo" che unisce la base in alluminio Sp. 15 mm in metallo verniciato Ottone Anticato, Dark Bronze Anticato o Graphite Anticato e il top circolare disponibile in laccato opaco e lucido sp. 19 mm, marmo sp. 20 mm in tutte le varianti ed essenze sp. 19 mm opaca Rovere nero, Eucalipto, Ebano e Tabacco e lucida Ebano.

Lo stilo viene verniciato in abbinamento al colore del piano con combinazioni predefinite, che creano un elegante gioco di colori.

Series of Stiletto small tables with varying heights and diameters, consist of a "stem" connecting the base in aluminum th.15mm, varnished in Antique Brass, Antique Dark Bronze, or Antique Graphite, to the circular top. The top is available in matt and glossy lacquer th.19 m, marble in all variations th.20mm, or wood veneer th.19mm. in matt finishes such as Black Oak, Eucalyptus, Ebony, and Tobacco, and glossy Ebony.

The stem is painted to match the color of the top, featuring predefined combinations that create an elegant play of colors.

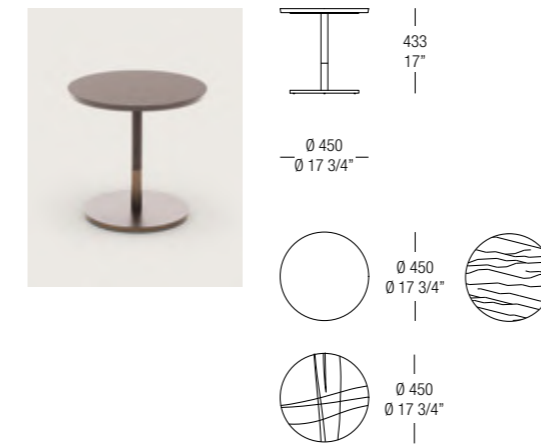
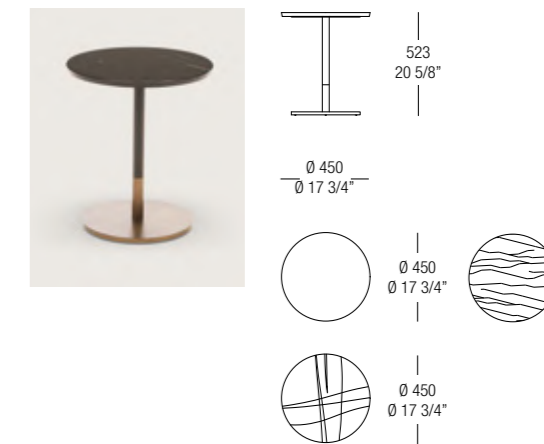
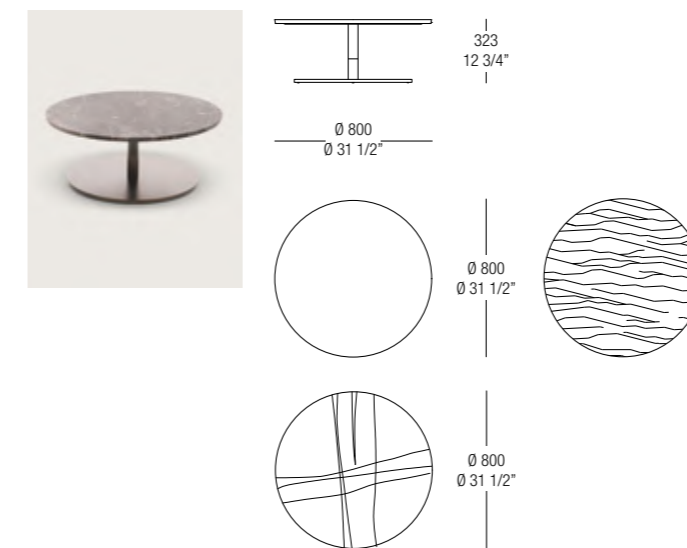
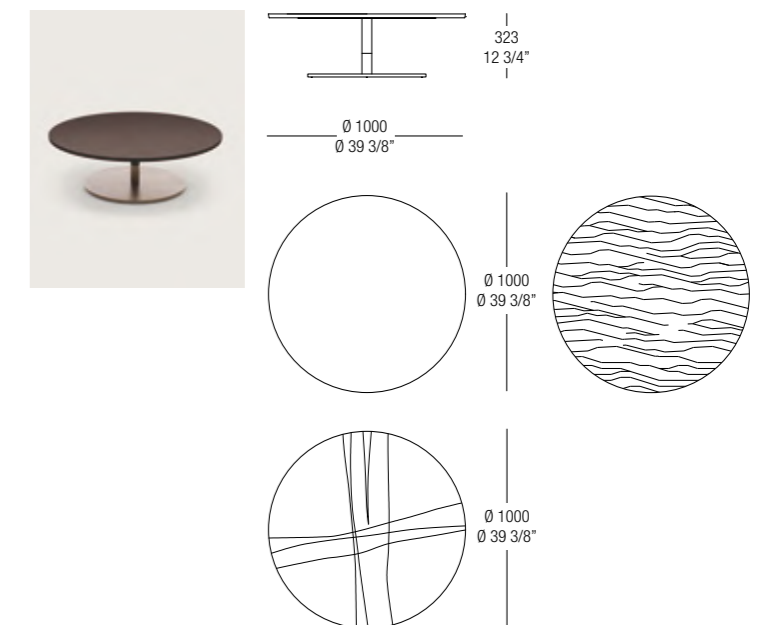
**TAVOLINO H. 433 \_ SMALL TABLE H. 433****TAVOLINO H. 523 \_ SMALL TABLE H. 523****TAVOLINO Ø 800 \_ SMALL TABLE Ø 800****TAVOLINO Ø 1000 \_ SMALL TABLE Ø 1000**

# JANUS

DESIGN: FRANCESCO LUCCHESI

È la peculiare struttura, caratterizzata da un accoppiamento di due doppie "C" in metallo, a catturare lo sguardo. Su di essa, disponibile in varie altezze e finiture, poggia il piano presentato in due soluzioni geometriche, tondo o semiovale, e in diversi materiali, marmo, legno e vetro. Un'armonia sinuosa sublimata dalla presenza di materiali pregiati sapientemente lavorati.

*The unique structure, characterised by the combination of two double C-shaped elements in metal, is what captures the eye first. Available in various different heights and finishes, the structure supports the table top (either round or semi-oval in shape), which can be finished in materials such as marble, wood and glass. It all adds up to a flowing design heightened by the use of the finest materials – all expertly handled, of course.*









**JANUS: TAVOLINO \_ SMALL TABLE**

Serie di tavolini Janus con struttura caratterizzata da un accoppiamento di due doppie "C" in metallo, in modo da formare una croce, con base nera e crociera oro. Su di essa poggia il piano tondo in vetro bisellato trasparente fumè sp. 12mm o semiovale disponibile in vetro trasparente fumè sp.12mm, essenza lucida e opaca sp. 22mm. in Rovere nero, Olmo Grey, Eucalipto, Ebano e Tabacco e in marmo sp. 20mm. tutte le varianti.

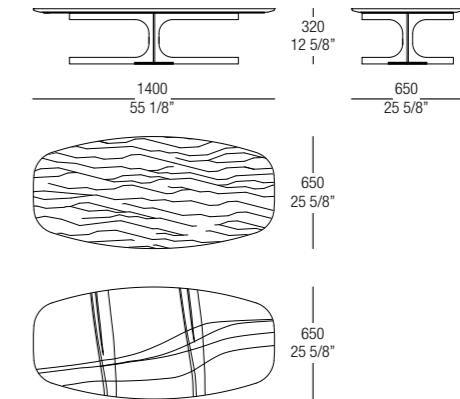
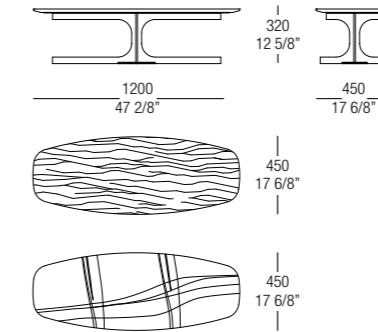
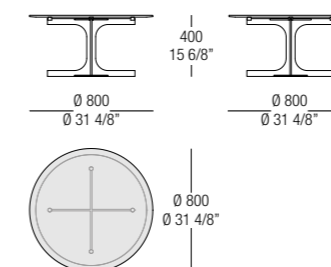
*Series of Janus small tables featuring a structure composed of two double "C" metal elements joined to form a cross, with a black base and gold crosspiece. The structure supports a round tabletop in smoked transparent beveled glass th.12 mm. or a semi-oval top available in smoked transparent glass th.12 mm, glossy and matt wood veneer th.22 mm. in Black Oak, Grey Elm, Eucalyptus, Ebony, and Tobacco, or marble th. 20 mm in all available variations.*

**TAVOLINO SEMIOVALE \_ SEMI-OVAL SMALL TABLE**

**TAVOLINO TONDO \_ ROUND SMALL TABLE**

# SIRIUS

DESIGN: ANDREI MUNTEANU

Esile e lucente foggia in metallo nichelato oro, esaltata dalle tre gambe tubolari saldate tra loro e disposte triangolarmente. Sono queste ultime a reggere il vassoio ribassato, luogo eletto ad alloggio del top in marmo, tocco delicato negli spazi dell'abitare contemporaneo.

*This sleek and shiny table in nickel-plated metal with a gold finish is supported by three tubular legs arranged in a triangle and soldered together. The legs support the sunken tray, which in turn holds the marble table top, bringing a delicate touch to contemporary spaces.*









---

**SIRIUS: TAVOLINO \_ SMALL TABLE**

Tavolino Sirius con struttura in metallo nichelato oro, le gambe tubolari saldate tra loro sono disposte triangolarmente. La struttura regge un vassoio ribassato dove alloggia il piano in marmo disponibile in tutte le varianti, che crea uno spessore totale di 40mm.

*Sirius small table with a structure in gold-nickel-plated metal. The tubular legs, welded together, are arranged in a triangular formation. The structure supports a recessed tray that houses the marble top, available in all variations, creating a total thickness of 40 mm.*

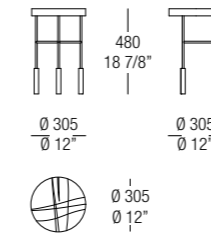
---

**TAVOLINO \_ SMALL TABLE**

# RIALTO

DESIGN: CR&S MISURAEMME

Un sapiente incrocio di piani e linee fluide da vita a Rialto, la cui peculiare struttura – due piani tondeggianti con uno spicchio ad angolo retto, collegati tra loro da un geometrico basamento – gli consente di vivere con una duplice funzione negli spazi domestici. Singolarmente, come tocco inaspettato ed estroso, oppure come accompagnamento discreto da porre ad angolo di imbottiti, pouf e letti. Ancora una volta la creatività sposa la funzionalità dando vita a una raffinata lavorazione.

*A stunning combination of surfaces and fluid lines is at the heart of Rialto, whose unique structure – two rounded surfaces paired with a further segment on a right angle and joined together by a geometric base – allows it to fulfil two roles within the domestic setting. It can either be deployed as a stand-alone piece – something unexpected and brilliant – or as a subtle complement to soft furniture, pouf or even beds. Rialto is yet another example of the possibilities when creativity and practicality meet expert manufacturing.*







**RIALTO: TAVOLINO \_ SMALL TABLE**

I tavolini Rialto sono disponibili in due versioni: con piano rotondo al 100% e con piano aperto a 3/4 di cerchio. La base metallica della struttura è uguale per entrambe le varianti ed è un 3/4 di cerchio verniciato ottone anticato, mentre il corpo che sostiene il top è un abbinamento di linee rette e circolari in metallo verniciato nero. Il piano in vetro bisellato sp.12mm. è in vetro trasparente fumè. La versione 3/4 può essere utilizzata come tavolino complementare da affiancare all'angolo del divano o di un pouf.

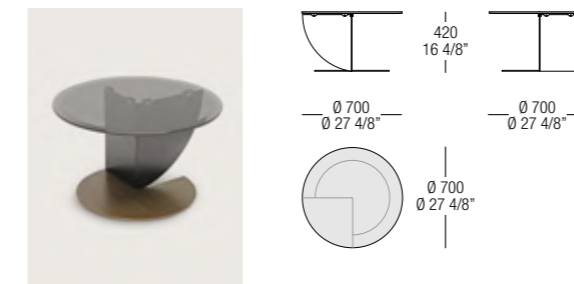
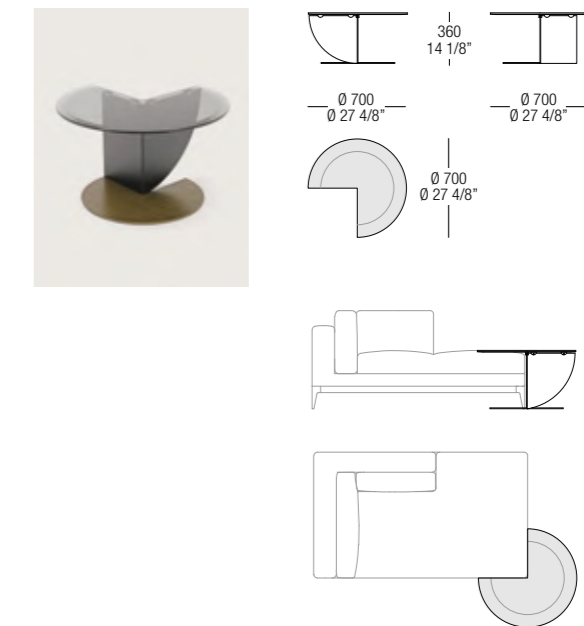
*The rialto small tables are available in two versions: one with a fully round top 100% and the other with a 3/4 circle top. The metallic base structure is the same for both variants, featuring a 3/4 circle design varnished in antique brass, while the structure supporting the top combines straight and circular lines in black varnished metal. The beveled glass top th.12mm. is made of fumè transparent glass. The 3/4 version can be used as a complementary table, perfect for placing next to a sofa corner or a pouf.*

**TAVOLINO TONDO \_ ROUND SMALL TABLE**

**TAVOLINO 3/4 DI CERCHIO \_ SMALL TABLE 3/4 CIRCLE TOP**



# MOAI

DESIGN: RICCARDO GUSSONI

L'incantevole massello di tiglio verniciato conquista l'attenzione dell'intero ambiente in cui viene inserito. Il richiamo culturale è esplicito: le statue monolitiche dell'Isola di Pasqua, un concentrato di timore reverenziale e bellezza senza tempo. La caratteristica struttura a clessidra è attraversata da un cilindro, nella zona centrale, permettendo la disposizione di nuovi piani d'appoggio e il gioco di movimenti tra volumi massicci.

*The enchanting painted lime wood captures the attention of the entire space in which it is placed. The cultural reference is explicit: the monolithic statues of Easter Island, a blend of reverential awe and timeless beauty. The hourglass-shaped structure is traversed by a cylinder in the central area, allowing for the arrangement of new surfaces and the interplay of movements between massive volumes.*

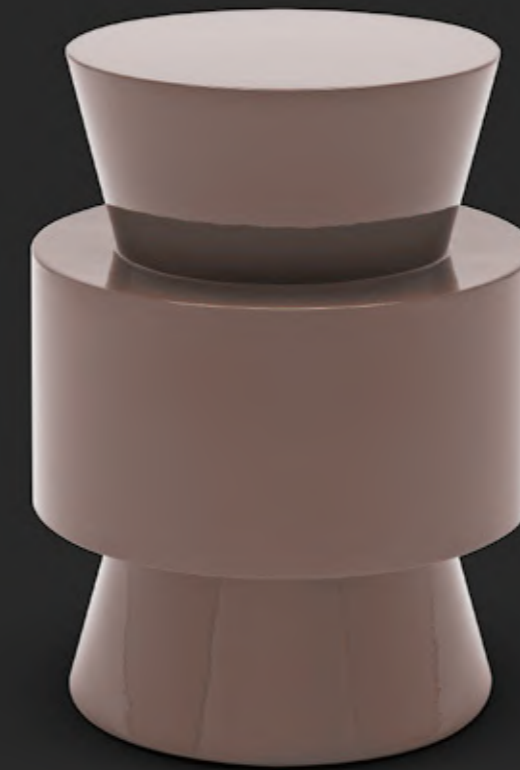







---

**MOAI: TAVOLINO \_ SMALL TABLE**

Moai, tavolino cilindrico in massello di tiglio disponibile nelle finiture verniciato laccato opaco e lucido.

*Moai, cylindrical small table in solid lime wood, available in matt and glossy lacquered finishes.*

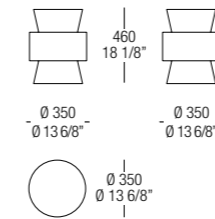
---

**TAVOLINO \_ SMALL TABLE**

# MADIE *SIDEBOARDS*

Una raccolta di proposte contraddistinte da matericità, aspetti e stili diversi firmate da designer di spicco. Encomiabili creazioni capaci di adattarsi liberamente e naturalmente a ogni ambiente, esprimendo a pieno la filosofia progettuale e del su misura alla base dell'intera produzione.

*A collection of pieces by renowned designers that excel in their use of materials and their array of designs and styles. These stunning creations can seamlessly adapt to any space, encapsulating the bespoke design philosophy that underpins the MisuraEmme way.*



**Shibuya**  
Studio 63

—  
262



**Eros**  
Studio 63

—  
276



**Milvian**  
Francesco Lucchese

—  
286

# SHIBUYA

DESIGN: STUDIO 63

Shibuya nasce dall'idea di creare un'elegante madia, alta e leggera, che avvolga con grazia materiali preziosi, come un tesoro custodito in uno scrigno. Oltre alla sua funzione primaria di contenimento, si trasforma in un piccolo bar dall'ispirazione retrò degli anni '70 con un'eleganza senza tempo. La madia Shibuya incarna un'estetica raffinata, avvalendosi di finiture pregiate come l'essenza e il metallo verniciato in una lussuosa tonalità di Canna di fucile lucido. La struttura si eleva con grazia, sostenendo ante in vetro rete e schienali in tecno-marmo Calacatta Oro. Queste madie incarnano un connubio perfetto tra l'ingegneria raffinata di MisuraEmme e la ricerca emotiva dello Studio63, trasmettendo un'eleganza senza tempo e una funzionalità impeccabile.

*Shibuya was born from the idea of creating an elegant sideboard, tall and lightweight, that gracefully envelops precious materials, like a treasure that is stored in a box.*

*Beyond its primary function of storage, it transforms into a small bar with a retro inspiration from the 70's, offering timeless elegance. The Shibuya sideboard embodies a refined aesthetic, utilizing exquisite finishes such as wood veneer and metal painted in a luxurious gloss Gunmetal shade.*

*The structure rises gracefully, supporting doors in mesh glass and backs in Calacatta Oro techno-marble. These sideboards represent the perfect fusion of MisuraEmme's refined engineering and Studio63's emotional design research, conveying timeless elegance and flawless functionality.*















**SHIBUYA: MADIA \_ SIDEBOARD**

Le madie Shibuya sono disponibili in due altezze diverse e offrono funzionalità di contenimento e modulo bar.

La madia bassa presenta una struttura in metallo, disponibile in tutte le finiture metalliche lucide o opache, con spalle e cassetti in essenza Rovere Nero opaco e schienali in Tecnomarble Calacatta Oro o Specchio naturale. I cassetti sono dotati di un meccanismo di apertura a completa scomparsa e un interno rifinito nella stessa essenza della struttura.

Inoltre, la madia bassa è composta da tre moduli, il centrale è dotato di un'anta a ribalta serigrafata in vetro rete, mentre i laterali sono roteabili e intercambiabili e possono fungere da paravento.

La madia alta, invece, è composta da un unico modulo con ante battenti serigrafate in vetro rete, struttura in metallo verniciato lucido o opaco e spalle e cassetti in essenza lucida Ebano. Lo schienale è disponibile in Tecnomarble Calacatta Oro o in specchio naturale.

*Shibuya sideboards are available in two different heights and offer storage and bar module functionality.*

*The low sideboard features a metal frame, available in all gloss or matte metal finishes, with shoulders and drawers in matte Black Oak essence and backs in Tecnomarble Calacatta Oro or Natural Mirror. The drawers feature a fully concealed opening mechanism and an interior finished in the same essence as the frame.*

*In addition, the low sideboard is composed of three modules, the middle one is equipped with a flap door screen-printed in mesh glass, while the side ones are rotatable and interchangeable and can serve as a screen.*

*The tall sideboard, on the other hand, consists of a single module with hinged doors screen-printed in mesh glass, a gloss or matte painted metal frame, and shoulders and drawers in glossy Ebony essence. The back is available in Tecnomarble Calacatta Oro or natural mirror.*

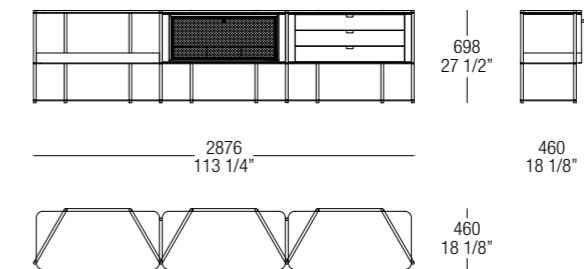
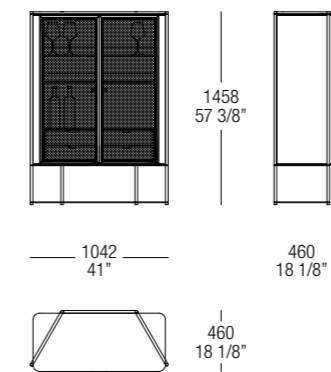
**MADIA BASSA \_ LOW SIDEBOARD****MADIA ALTA \_ HIGH SIDEBOARD**

# EROS

DESIGN: STUDIO 63

La collezione Eros, accoglie un mobile contenitore pensato per la zona giorno, grazie al contrasto cromatico e materico e al design etereo, conferisce esclusività a ogni ambiente living. Complemento d'arredo di grande raffinatezza e ricercatezza, disponibile in due versioni, è caratterizzato da un'elegante ed essenziale struttura metallica a sostegno del contenitore in essenza rovere nero e del top in marmo.

*The Eros collection features a storage unit designed for the living area, bringing exclusivity to any living space through its ethereal design and contrasting materials and colors. This refined and sophisticated furniture piece, available in two versions, is distinguished by its elegant and minimalist metal structure supporting a Black Oak veneer storage unit and a marble top.*







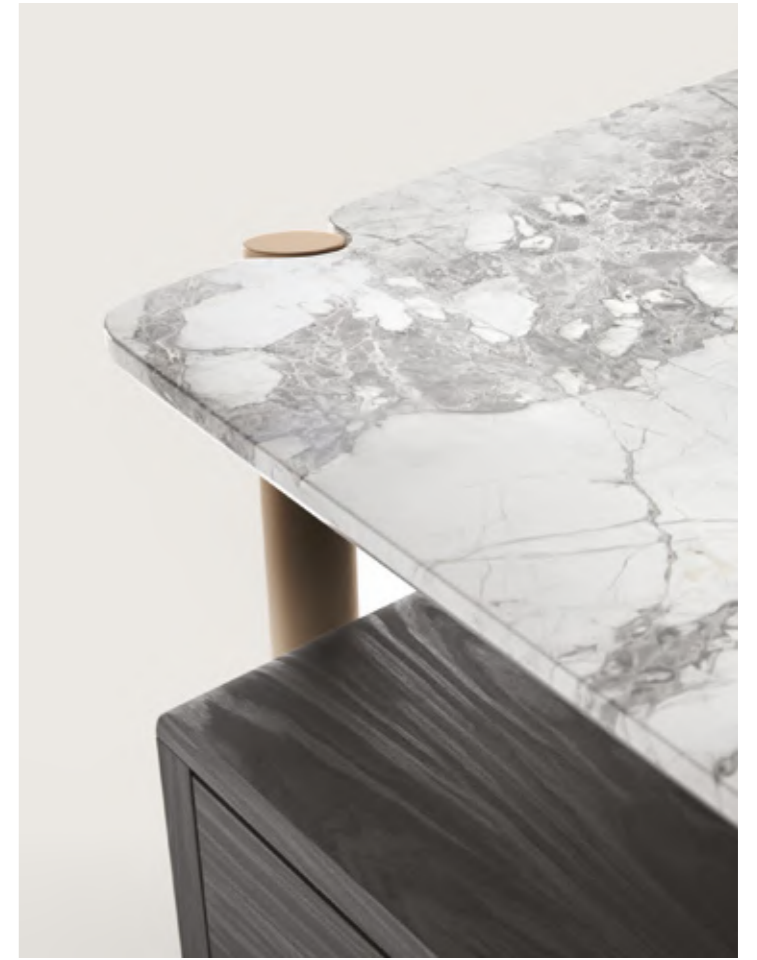

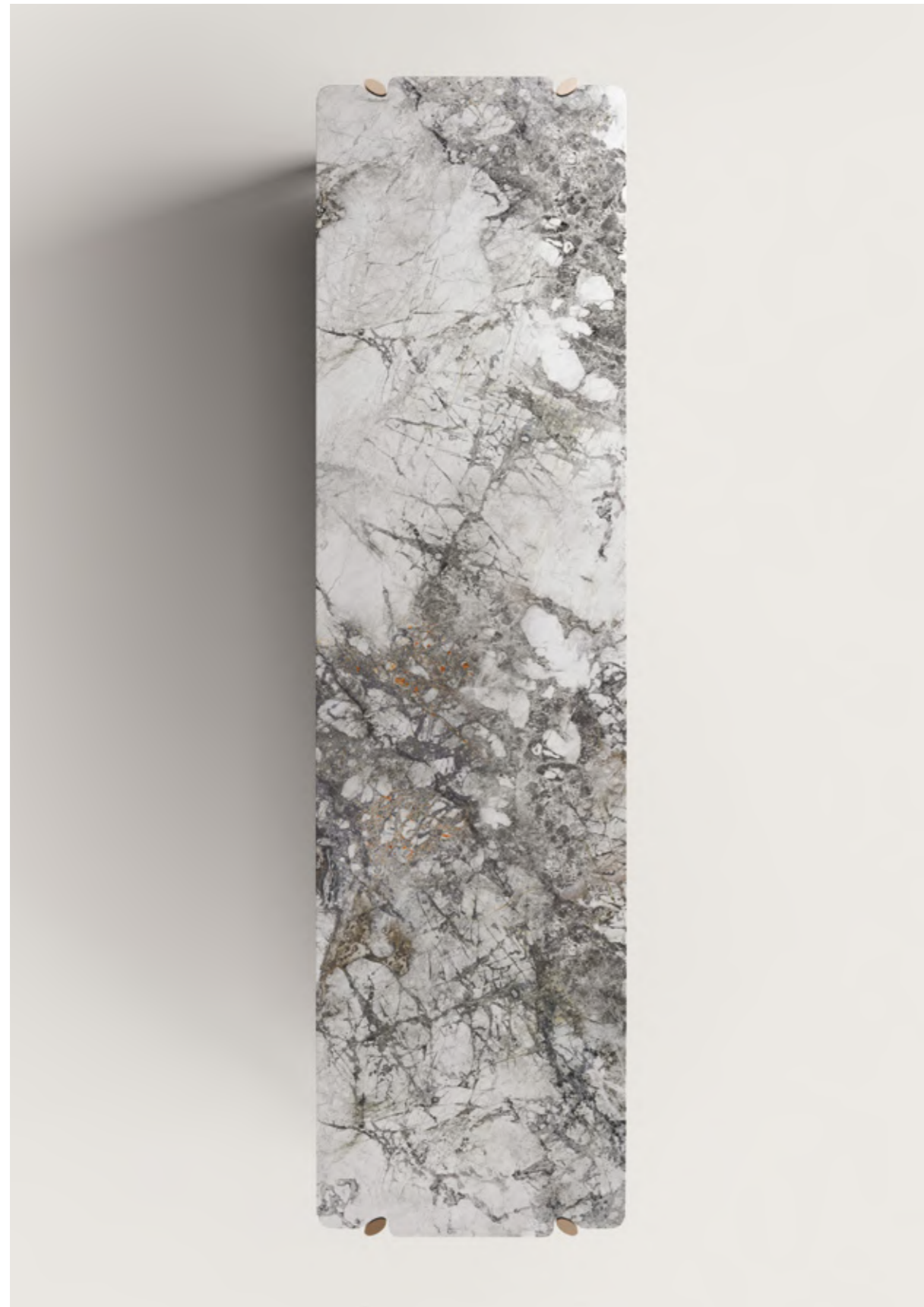

---

**EROS: MADIA \_ SIDEBOARD**

La madia Eros, contraddistinta per il sofisticato dialogo tra i diversi materiali: metallo, marmo, legno, si presenta in due diverse altezze: in versione bassa h. 503 mm e alta h. 683 mm.

La struttura di diametro ovale metallico, disponibile in tutte le finiture metallizzate lucide e opache, sostiene i cassetti in essenza opaca Rovere nero e il pregiato piano di appoggio disponibile in tutte le varianti del marmo. Il meccanismo di apertura è a completa scomparsa e l'interno dei cassetti è in melaminico Primo Fiore. Il piano è caratterizzato da una sofisticata rientranza all'interno della quale è inserita la struttura in metallo.

*The Eros sideboard, defined by their sophisticated interplay of materials metal, marble, and wood is available in two heights: a low version at 503 mm and an high version at 683 mm.*

*The oval-shaped metal structure, available in all glossy and matt metallic finishes, supports matt Black Oak veneer drawers and a premium top available in all marble variants. The opening mechanism is fully concealed, and the drawer interiors are finished in Primo Fiore melamine. The top is distinguished by a refined recess that integrates the metal structure seamlessly.*

---

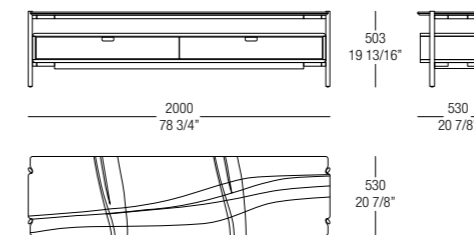
**MADIA BASSA \_ LOW SIDEBOARD**

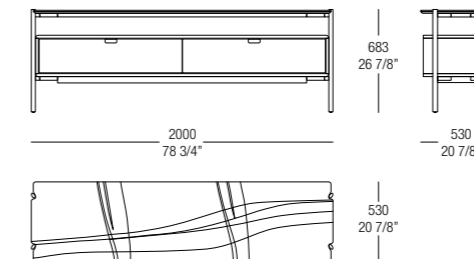

---

**MADIA ALTA \_ HIGH SIDEBOARD**



# MILVIAN

DESIGN: FRANCESCO LUCCHESI

Sublimi suggestioni di gusto ricercato per Milvian, originale compenetrazione di esclusive linee e dettagli costruttivi di pregio. A incorniciare l'armoniosa struttura in essenza, le spalle sagomate, dettaglio piacevole per il tatto e richiamo garbato su cui indugiare per l'occhio, che proseguono fino a terra trasformandosi in squisiti piedini.

Un equilibrio sapiente a cui si aggiunge la preziosità del top da scegliere tra le numerose finiture presenti a catalogo.

*Milvian features some sublime and sophisticated styling, combining bold lines with the finest detailing. The flowing wood structure is framed by curved side panels, which feel pleasant to the touch and draw the gaze as they continue to the floor, where they get transformed gracefully into feet. There is a wonderful sense of balance to the piece, with customers able to choose the finish for the top from the large number of options in the range.*



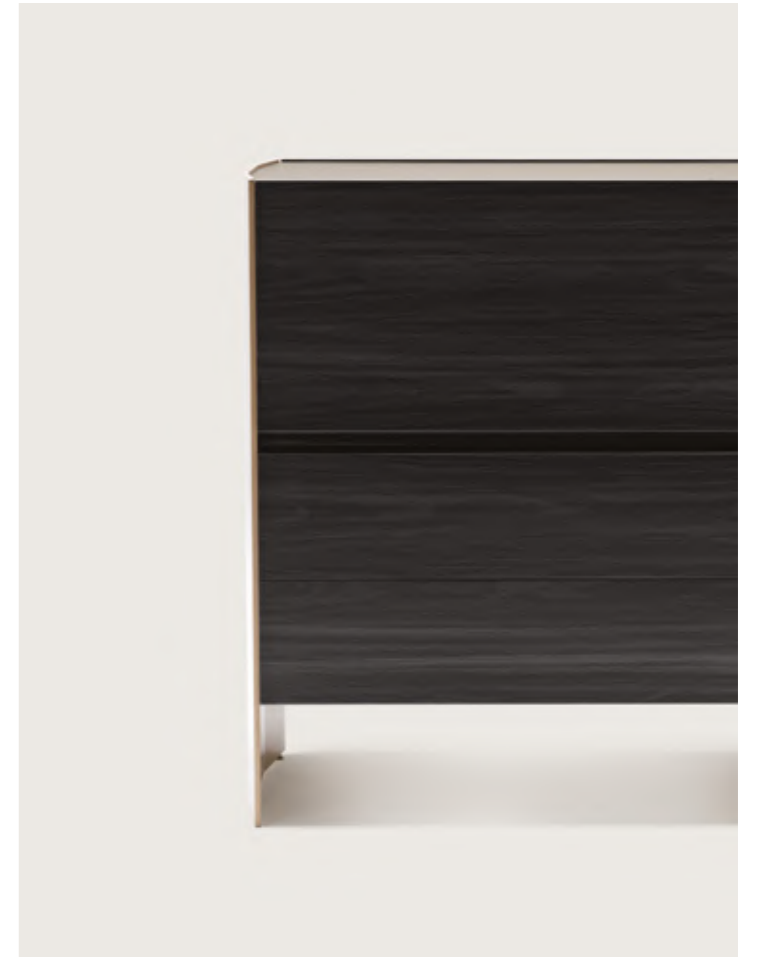



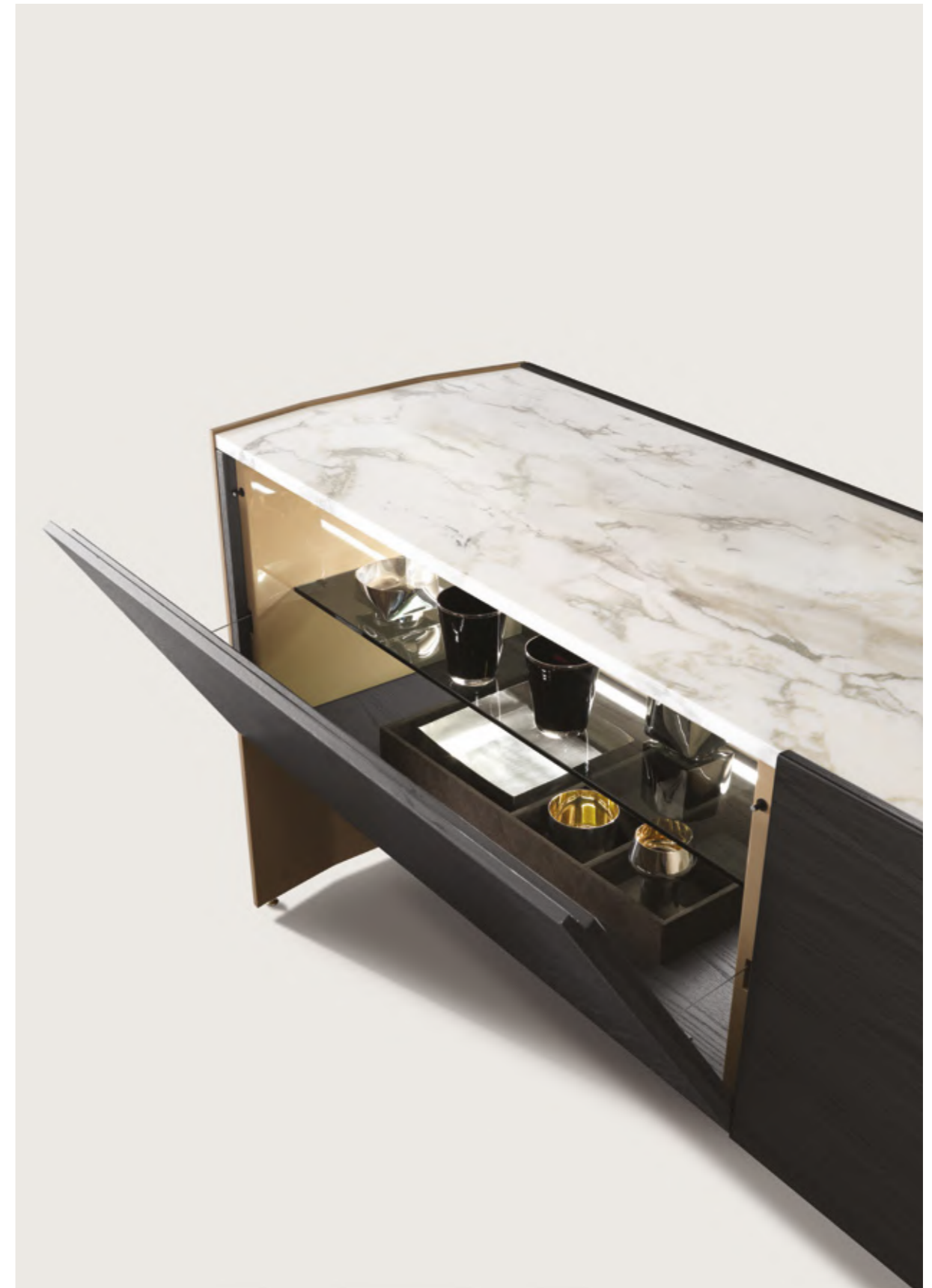

**MILVIAN: MADIA \_ SIDEBOARD**

Collezione Milvian disponibile in due soluzioni: madia alta e madia bassa. Disponibili anche le versioni con frontale fisso per utilizzo bifacciale (profondità 516 mm) o parete (profondità 504 mm).

La madia bassa è provvista di due ante con apertura a ribalta con interno in finitura laccato lucido Toffee o Marsala e meccanismo di apertura completamente a scomparsa, all'interno del vano è posizionato un ripiano in vetro trasparente fumé per la suddivisione degli spazi, l'interno è attrezzabile con un vassoio contenitore diviso in compartimenti rivestito in pelle.

La madia alta presenta un'apertura a ribalta principale per utilizzo bar con vano interno in finitura laccato lucido Toffee o Marsala, il meccanismo di apertura è a completa scomparsa; nella parte inferiore è dotata di due cassetti finitura interna primo fiore attrezzabili con optional di contenimento: portaposate e portaoggetti.

Spalle sagomate in alluminio verniciato opaco bronzo o canna di fucile. Frontali in essenza lucida o opaca nelle finiture: Rovere nero, Olmo Grey, Tabacco, ed Eucalipto. Il top è disponibile in marmo tutte le varianti sp. 20mm o in vetro acidato sp. 5 mm.

*Milvian Collection available in two configurations: tall sideboard and low sideboard. Available also with fixed fronts for dual-sided use (deep 516 mm \_ 20 5/16") or to wall (deep 504 mm \_ 19 13/16").*

*Low sideboard is equipped with two flap door down, glossy lacquered Toffee or Marsala interior, fully concealed opening mechanism, smoked transparent glass shelf for space division, optional leather-lined tray with compartments.*

*High sideboard is features a primary flap door down for bar use with an interior in glossy lacquered Toffee or Marsala, fully concealed opening mechanism, lower section with two Primo Fiore finish drawers, optional organizers for cutlery and accessories.*

*Contoured side panels in matt painted aluminum, Bronze or Gunmetal finishes. Fronts in glossy or matt wood veneers: Black Oak, Grey Elm, Tobacco, Eucalyptus. Top in marble all variants th.20mm or etched glass th.5 mm.*

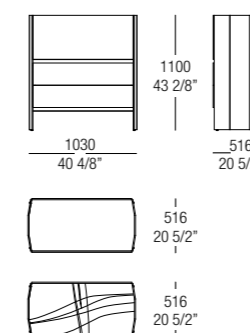
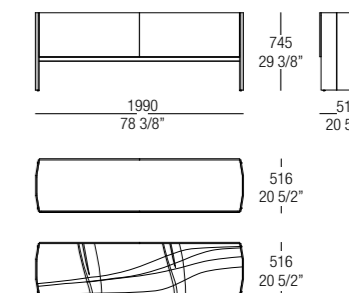
**MADIA ALTA \_ HIGH SIDEBOARD****MADIA BASSA \_ LOW SIDEBOARD**

# LETTI BEDS

Un letto MisuraEmme non è originale solo per quanto riguarda il "copyright" del progetto; la vera originalità risiede nella sua estetica, nella predisposizione, nella predisposizione all'abbinamento con mobili sempre diversi, nella sua capacità di essere protagonista in ogni ambiente.

*A MisuraEmme bed is not only original as far as "copyright" of a project is concerned, the true novelty lies in its aesthetic, its facility of being combined to different types of furniture, its capability of being a leader in every home environment.*



**Virgin**  
Mauro Lipparini

—  
298



**Margareth**  
Carlo Marelli e Massimo Molteni

—  
306



**Cosy**  
Mauro Lipparini

—  
314



**Sumo**  
Mauro Lipparini

—  
320



**Giorgia**  
Ennio Arosio

—  
326



**Eladio**  
Roberto Allievi e Alberto Viganò

—  
332

# VIRGIN

DESIGN: MAURO LIPPARINI

Letto dall'elegante forma scultorea, essenziale e accogliente, espressione della vocazione sartoriale di MisuraEmme, in grado di coniugare morbidezza e razionalità. Profili architettonici esaltano i volumi imbottiti e conferiscono al contempo un leggero segno grafico. Disponibile con cassone in indifferenti dimensioni. Si contraddistingue per la testata avvolgente, disponibile in tessuto o in pelle.

*Bed with an elegant sculptural shape, essential and welcoming, an expression of MisuraEmme's sartorial vocation, able to combine softness and rationality. Architectural profiles enhance the padded volumes and at the same time give a light graphic sign. Available with storage in different sizes. It stands out for its enveloping headboard, available in fabric or leather.*









**VIRGIN: LETTO \_ BED**

Virgin, letto dal design scultoreo, essenziale e accogliente, espressione della vocazione sartoriale di MisuraEmme, che unisce morbidezza e razionalità. I profili architettonici esaltano i volumi imbottiti, conferendo al contempo un elegante segno grafico.

La testata è composta da un pannello in multistrato curvato, rivestito con poliuretano espanso e copertura in vellutino accoppiato. Il contenitore è uno scatolato, anch'esso in multistrato rivestito con poliuretano espanso e copertura in vellutino.

Il fondo contenitore è realizzato in nobilitato Sp. 14mm, sollevabile tramite maniglia con due movimenti: alzata per riporre oggetti, sgancio e posizionamento orizzontale per rifare il letto. Il sollevamento è assistito da pistoni 1150 NW. Attenzione: i pistoni del meccanismo di sollevamento della rete sono progettati per sollevare la rete con un peso massimo del materasso di 35 kg (per le reti 1600x2000 e 1800x2000).

Il giroletto a rete fissa è composto da uno scatolato in multistrati rivestito con poliuretano espanso e copertura con accoppiato di vellutino. Rete con telaio e doghe in legno in appoggio sui traversi in metallo verniciato.

Letto compatibile con materassi nelle dimensioni 1530, 1600, 1800 e 1930 cm.

Il rivestimento è disponibile in tessuto sfoderabile o in pelle non sfoderabile. Le versioni in velluto e in ecopelle non sono disponibili. È accessibile una variante bicolor con finiture diverse per il rivestimento della testata e del giroletto, utilizzabile anche in centro stanza.

*Virgin, a bed with a sculptural, essential, and welcoming design, embodying MisuraEmme's tailor-made vocation, blending softness and rationality. The architectural profiles highlight the padded volumes, while also giving an elegant graphic touch.*

*The headboard is made from a curved plywood panel, upholstered with expanded polyurethane and a velvety cover. The container is a box structure, also in plywood, upholstered with expanded polyurethane and a velvety cover.*

*The container bottom is made of th.14mm laminated board and can be lifted using a handle in two movements: lifting to store items, disengaging and repositioning horizontally to remake the bed. The lifting mechanism is assisted by 1150 NW pistons. Please note: the pistons in the lifting mechanism are designed to lift the base with a maximum mattress weight of 35 kg (for the 1600x2000 and 1800x2000 sizes).*

*The fixed net bed frame is composed of a boxed in plywood covered with polyurethane foam and cover with coupled velveteen. The slatted base features a wooden frame and slats resting on painted metal crossbars.*

*The bed is compatible with mattresses in the dimensions of 1530, 1600, 1800, and 1930 cm. Is available in removable fabric or non-removable leather. Velvet and eco-leather versions are not available. A bicolor version is accessible, featuring different finishes for the headboard and bed frame upholstery, also usable in the center of the room.*

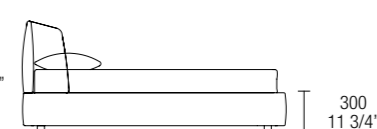
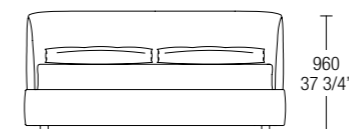
**LETTO CON RETE FISSA E LETTO CONTENITORE CON RETE A 2 MOVIMENTI \_ BED WITH FIXED BEDSPRING AND STORAGE BED WITH 2-POSITION BEDSPRING**

A	B	(QS)	(KS)
*1880	*2080	1810	2210
*74"	*81 7/8"	71 2/8"	87"

DIM. MATERASSO _ MATTRESS SIZES			
1600	1800	1530	1930
63"	70 7/8"	60 2/8"	76"

A / B	A / B	(QS / KS)
*2280	2380	2300
*89 6/8"	93 3/4"	90 1/2"

DIM. MATERASSO _ MATTRESS SIZES		
2000	2100	2020
78 6/8"	82 5/8"	79 1/2"

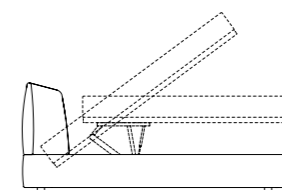
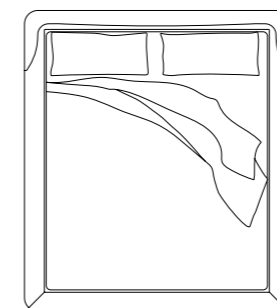

\* Rete alzabile disponibile solo con queste misure  
\* Raisable bedspring available only for these sizes

# MARGARETH

DESIGN: CARLO MARELLI E MASSIMO MOLTENI

Con il suo design etereo e flessuoso, unito alla più evoluta tecnologia dei materiali, Margareth è un compendio di eleganza e leggerezza. L'armoniosa testata dà vita a seducenti giochi di chiaroscuro grazie al rivestimento di impeccabile fattura sartoriale.

Dettaglio di stile, l'originale piedino sagomato in rovere massello dalla forma snella, per un letto nell'insieme agile e leggero, un tutt'intero posizionabile anche a centro stanza.

*With its ethereal, supple design, coupled with the most technologically advanced materials, Margareth is the epitome of elegance and lightness. The harmonious steel headboard creates a seductive interplay of light and shade, thanks to the impeccably tailored covering. A notable stylish detail is the original, slender shaped solid oak leg, resulting in a light and agile bed, an all-round bed that can also be placed in the middle of a room.*







**MARGARETH: LETTO \_ BED**

L'elegante letto Margareth in massello è adatto per essere posizionato in centro stanza grazie alla meticolosa attenzione dei dettagli in ogni suo lato.

La testata è in metallo decappato termosaldato con tamponi di poliuretano espanso, con copertura in tessuto in fibra poliestere tesata.

Il Giroletto ha la rete fissa in faggio massello, con piedi sagomati in massello rovere Olmo Grey, Cenere, Rovere nero, Tabacco ed Eucalipto. La rete strutturale piana è in metallo con doghe in legno e piede centrale di sostegno. Il letto è compatibile con materassi nelle dimensioni 1750 / 1930 cm. Giroletto non smontabile.

Il rivestimento è disponibile in tessuto, ecopelle e pelle con bordino tessuto in tinta o in contrasto, sfoderabile solo il giroletto. La versione in cuoio non prevede il bordino e non è sfoderabile, disponibile nelle seguenti finiture: bianco latte, bianco ghiaccio, moro scuro, grigio e tabacco.

*The elegant Margareth solid wood bed, is ideal for positioning in the center of a room thanks to meticulous attention to detail on every side.*

*The headboard is made of heat-welded decapé metal with polyurethane foam inserts, covered in stretched polyester fiber fabric.*

*The bed frame features a fixed solid beech slat base, with shaped legs in solid wood available in Grey Elm, Cenere, Black Oak, Tobacco, and Eucalyptus finishes. The structural flat slat base is metal with wooden slats and a central support leg. The bed is compatible with mattresses measuring 1750 / 1930 mm. The bed frame is non-detachable.*

*The upholstery is available in fabric, eco-leather, and leather, with matching or contrasting fabric piping; the bed frame cover is removable. The leather version does not feature piping and is non-removable, available in the following finishes: milk white, ice white, dark brown, gray, and tobacco.*

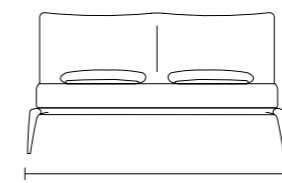
**LETTO CON RETE PIANA STRUTTURALE \_ BED WITH FLAT STRUCTURAL BEDSPRING**

1050  
41 3/8"

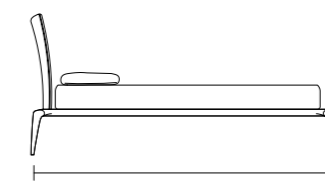

340  
13 3/8"

A	(KS)
1930	2110
76"	83 1/8"

**DIM. MATERASSO \_ MATTRESS SIZES**

1750	1930
68 7/8"	76"

A	(KS)
2280	2300
89 3/4"	90 1/2"

**DIM. MATERASSO \_ MATTRESS SIZES**

2000	2020
78 3/4"	79 1/2"

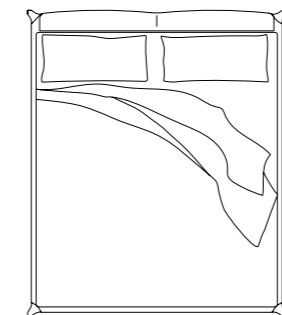

# COSY

DESIGN: MAURO LIPPARINI

Cosy riassume il concetto di semplicità, leggerezza ed ecletticità.

L'originale testata gioca con le linee oblique e il dinamismo delle geometrie.

Inserti a contrasto in pelle scamosciata la incorniciano lateralmente animando cromaticamente le forme morbide della struttura. Una zona notte dall'allure ricercata, dove la compenetrazione di volumi confortevoli e l'utilizzo di molteplici rivestimenti sottolineano l'eleganza formale degli elementi.

*Cosy sums up the concept of simplicity, lightness and versatility.*

*The original headboard plays with oblique lines and dynamic geometries.*

*Contrasting suede inserts frame the sides, animating the soft forms of the structure with colour.*

*A night area with a sophisticated allure, in which the intermingling of comfortable volumes*

*And the use of multiple coverings emphasizes the formal elegance of the elements.*



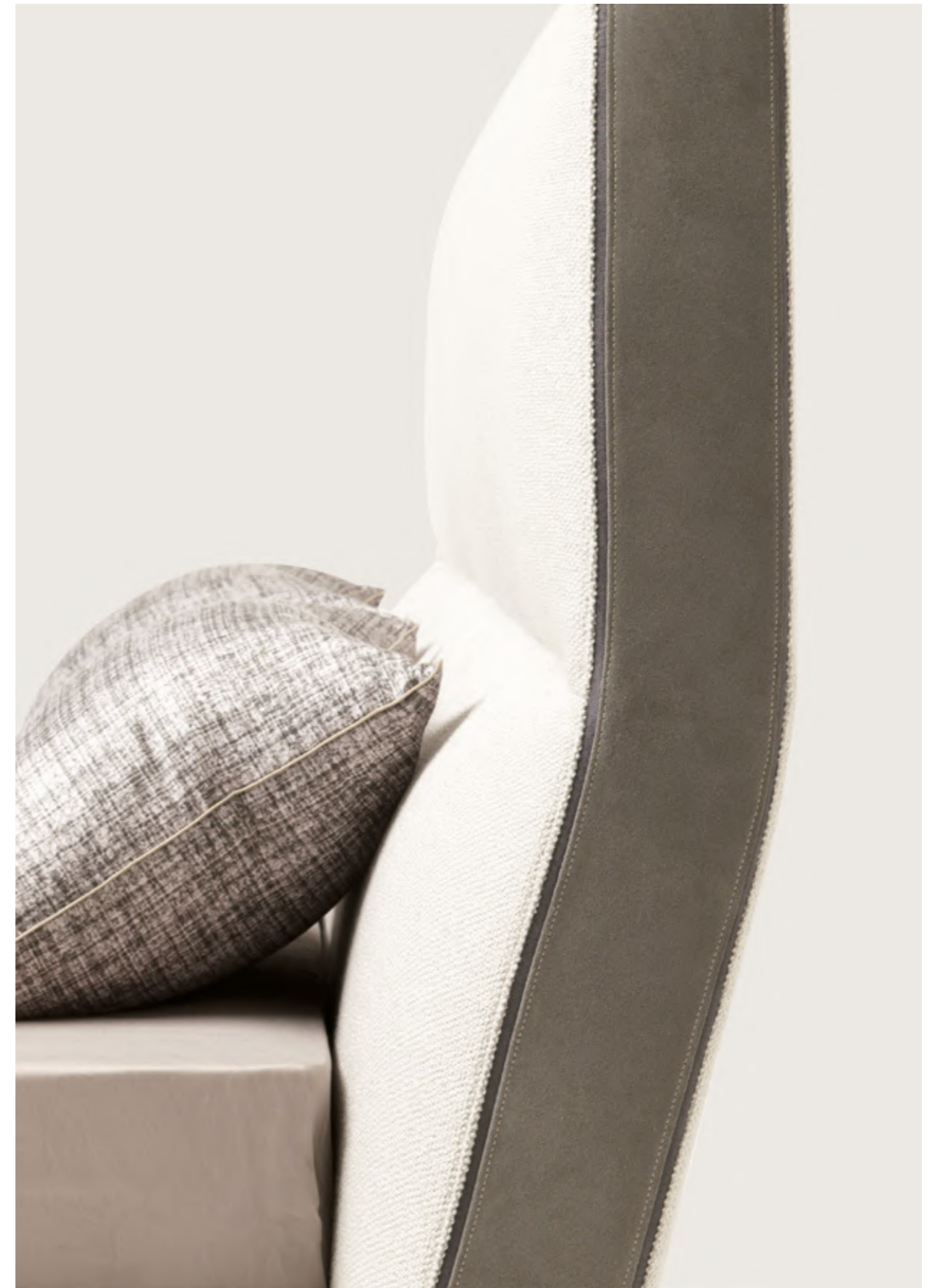



**COZY: LETTO \_ BED**

Cosy combina semplicità, leggerezza ed ecletticità con dettagli sartoriali e un design contemporaneo.

La testata è formata da un pannello in multistrato curvato rivestito con poliuretano espanso e copertura con accoppiato di vellutino. Il contenitore è composto da un pannello di particelle di legno in classe di formaldeide E1, nobilitato con carte decorative impregnate di resine melamminiche.

Il modello con rete alzabile presenta il fondo contenitore in nobilitato Sp.14mm. alzabile tramite maniglia e compatibile con materassi nelle dimensioni 1600 / 1800 cm. La rete alzabile è a 2 movimenti con telaio e doghe in legno è studiata per riporre oggetti nel contenitore, con sgancio e posizionamento orizzontale per rifare il letto. Sollevamento con pistoni 1150 NW. - Attenzione: i pistoni del meccanismo di sollevamento rete sono predisposti per alzare la rete con il peso del materasso Kg.35 max (sia per la rete 1600x2000 che per la rete 1800x2000).

La rete fissa ha un telaio e doghe in legno in appoggio su traversi in metallo verniciato. Il modello con rete fissa presenta un telaio e doghe in legno in appoggio su traversi in metallo verniciato. Letto compatibile con materassi delle dimensioni 1530 / 1600 / 1800 / 1930 cm.

Il giroletto e la testata imbottiti si possono rivestire in tessuto, ecopelle e pelle sfoderabili. C'è la possibilità di rivestire la fascia della cornice della testata con tessuto, ecopelle o pelle, in finitura diversa dal rivestimento del letto.

Modello adatto per essere posizionato in centro stanza grazie alla meticolosa attenzione dei dettagli in ogni suo lato.

*Cosy combines simplicity, lightness, and versatility with tailored details and a contemporary design.*

*The headboard is made of panel in bent plywood, covered with polyurethane foam and cover with coupled velveteen. The storage compartment is made of E1 formaldehyde-class particleboard, coated with decorative paper impregnated with melamine resins.*

*The model with a raisable bedspring features a 14mm-thick coated bottom panel, liftable via a handle, and compatible with mattresses measuring 1600 / 1800 mm. The dual-lift mechanism bedspring, with a frame and wooden slats, is designed to store objects in the compartment. It includes a release and horizontal positioning system for easier bed-making. Lift is powered by 1150 NW pistons. - Attention: The pistons of the lift mechanism are calibrated to raise the bedspring with a mattress weight of up to 35 kg (both for the 1600x2000 mm and 1800x2000 mm bases).*

*The fixed bedspring has a frame and wooden slats resting on painted metal crossbars. The fixed bedspring model features a frame and wooden slats supported by painted metal crossbars. It is compatible with mattresses measuring 1530 / 1600 / 1800 / 1930 mm.*

*The upholstered bed frame and headboard can be covered in removable fabric, eco-leather, or leather. There is the option to cover the edge of the headboard frame with fabric, eco-leather, or leather in a finish different from the bed's upholstery.*

*This model is suitable for placement in the center of the room, thanks to meticulous attention to detail on every side.*

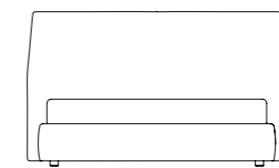
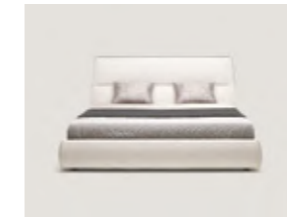
**LETTO CON RETE FISSA - LETTO CONTENITORE CON RETE CON MOVIMENTO MANUALE/ELETRICO**  
**BED WITH FLAT BEDSPRING - STORAGE BED WITH LIFTABLE BEDSPRING WITH MANUAL/ELECTRIC MOVEMENT**

1130  
44 1/2"

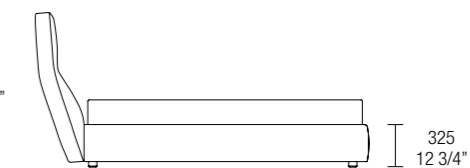

325  
12 3/4"

A	B	(QS)	(KS)
* 1880	* 2080	1810	2210
* 74"	* 81 7/8"	71 2/8"	87"

**DIM. MATERASSO \_ MATTRESS SIZES**  
1600 | 1800 | 1530 | 1930  
63" | 70 7/8" | 60 2/8" | 76"

A / B	A / B	(QS / KS)
* 2360	2460	2380
* 92 7/8"	96 7/8"	93 3/4"

**DIM. MATERASSO \_ MATTRESS SIZES**  
2000 | 2100 | 2020  
78 3/4" | 82 5/8" | 79 1/2"

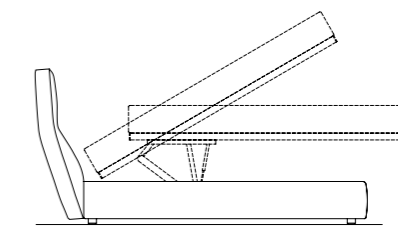
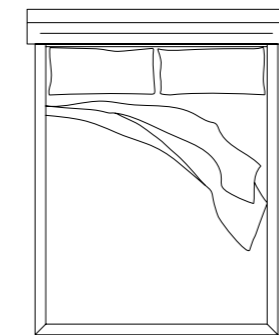

\* Rete alzabile disponibile solo con queste misure  
\* Raisable bedspring available only for these sizes

# SUMO

DESIGN: MAURO LIPPARINI

Il letto Sumo è la quintessenza del comfort e della morbidezza.

L'aspetto particolarmente distinto conferisce a questo letto imbottito una sofisticata eleganza, mentre le sue forme generose suggeriscono una comodità avvolgente, evocando tranquillità e relax. La consueta cura artigianale di ogni piccolo dettaglio mette in risalto gli accostamenti dei diversi materiali, evidenziando le qualità estetiche del prodotto.

*The Sumo bed is the epitome of comfort and softness. Its very distinct look lends this upholstered bed sophisticated elegance, while its generous shape suggests enveloping comfort, evoking tranquillity and relaxation. The usual craftsmanship of every little detail highlights the combinations of different materials, emphasizing the product's aesthetic qualities.*





**SUMO: LETTO \_ BED**

Sumo, letto imbottito dall'aspetto particolarmente distinto che conferisce una sofisticata eleganza, mentre le sue forme generose suggeriscono un comfort avvolgente.

La testata è ornata da un pannello di particelle di legno in classe di formaldeide E1 curvato rivestito con poliuretano espanso e copertura con accoppiato di vellutino. Il contenitore è composto da un pannello di particelle di legno in classe di formaldeide E1, nobilitato con carte decorative impregnate di resine melaminiche.

Il modello con rete alzabile presenta il fondo contenitore in nobilitato Sp.14mm. alzabile tramite maniglia è compatibile con materassi nelle dimensioni 1600 / 1800 cm. La rete alzabile è a 2 movimenti con telaio e doghe in legno è studiata per riporre oggetti nel contenitore, con sgancio e posizionamento orizzontale per rifare il letto. Sollevamento pistoni 1150 NW. - Attenzione: i pistoni del meccanismo di sollevamento rete sono predisposti per alzare la rete con il peso del materasso Kg.35 max (sia per la rete 1600x2000 che per la rete 1800x2000).

Il letto a rete fissa ha un telaio e doghe in legno in appoggio su traversi in metallo verniciato.

Il letto a rete con movimento manuale ed elettrico è predisposto di traversi in metallo verniciato per appoggio rete. Entrambi sono compatibili con materassi nelle dimensioni 1530 / 1600 / 1800 / 1930 cm.

Il giroletto e la testata imbottiti si possono rivestire in tessuto, ecopelle e pelle. Soderabile unicamente il giroletto. Possibilità di rivestire la parte frontale della testata con tessuto o pelle, in finitura diversa dal rivestimento del giroletto e della parte posteriore della testata.

Adatto per essere posizionato in centro stanza grazie alla meticolosa attenzione dei dettagli in ogni suo lato.

Sumo, a particularly distinguished upholstered bed that exudes sophisticated elegance, while its generous shapes suggest a enveloping comfort.

The headboard is made of class E1 wood particleboard, finished with decorative melamine facing. Covered with polyurethane foam and cover with coupled velveteen. The storage compartment is made of a panel of wood particles with E1 formaldehyde class, laminated with decorative papers impregnated with melamine resins.

The model with an raisable bedspring has a storage bottom made of 14mm laminated board, which can be raised using a handle. It is compatible with mattresses measuring 1600 / 1800 mm. The raisable bedspring operates with two movements and has a wooden frame and slats, designed to store items in the compartment. The base can be released and positioned horizontally for making the bed. Lifting pistons 1150 NW. Note: The pistons of the lifting mechanism are designed to raise the bed base with the mattress weighing a maximum of 35 kg (for both the 1600x2000 and 1800x2000 bases).

The fixed bedspring has a wooden frame and slats resting on metal crossbars.

The bed with manual and electric movement bedspring is equipped with painted metal crossbars for base support. Both options are compatible with mattresses measuring 1530 / 1600 / 1800 / 1930 mm.

The upholstered bed frame and headboard can be covered in fabric, eco-leather, and leather. Only the bed frame is removable. The front part of the headboard can be covered in fabric or leather in a finish different from the bed frame and the back of the headboard.

This model is suitable for placement in the center of the room, thanks to meticulous attention to detail on every side.

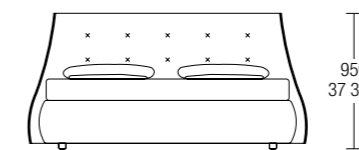
**LETTO CON RETE FISSA - LETTO CONTENITORE CON RETE CON MOVIMENTO MANUALE/ELETTRICO**  
**BED WITH FLAT BEDSPRING - STORAGE BED WITH LIFTABLE BEDSPRING WITH MANUAL/ELECTRIC MOVEMENT**

A	B	(QS)	(KS)
* 1970	* 2170	1900	2300
* 77 1/2"	* 85 3/8"	74 3/4"	90 1/2"

DIM. MATERASSO _ MATTRESS SIZES			
1600	1800	1530	1930
63"	70 7/8"	60 1/4"	76"

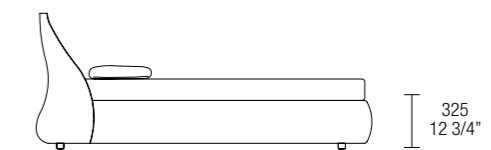

A / B	A / B	(QS / KS)
* 2350	2450	2370
* 92 1/2"	96 1/2"	93 1/4"

DIM. MATERASSO _ MATTRESS SIZES		
2000	2100	2020
78 3/4"	82 5/8"	79 1/2"

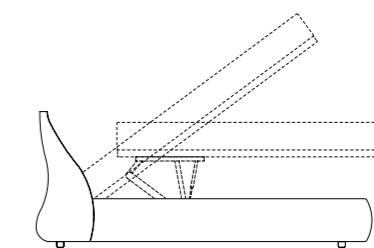
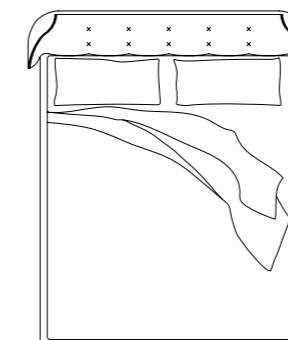

\* Rete alzabile disponibile solo con queste misure  
\* Raisable bedspring available only for these sizes

# GIORGIA

DESIGN: ENNIO AROSIO

Un'estetica di straordinaria essenzialità, capace di rendere comoda l'eleganza e più versatile il comfort. La testata del letto Giorgia, composta da due elementi autonomi con inclinazione regolabile, forma una curva leggera che offre alla zona notte un delicato segno di stile. Il calore del legno si coniuga a un'estrema funzionalità, frutto di suggestioni contemporanee.

*An extraordinarily simple aesthetic, which can make elegance comfortable and comfort more versatile. The headboard of the Giorgia bed, which consists of two independent elements with an adjustable tilt, forms a slight curve that lends the night area a delicate style. The warmth of the wood is combined with extreme functionality, the result of contemporary influences.*





**GIORGIA: LETTO \_ BED**

Il letto Giorgia rende comoda l'eleganza e più versatile la comodità.

La testata, composta da due elementi autonomi con inclinazione regolabile, forma una curva leggera che offre alla zona notte un delicato segno di stile. È formata da pannelli in multistrato curvato rastremato ricoperto MDF. Fresature orizzontali con effetto dogato. Pannello di supporto posteriore in agglomerato nobilitato stessa finitura dei pannelli reclinabili. Meccanismo reclinabile a 5 posizioni in acciaio zincato. Cerniera di rotazione pannelli reclinabili in ottone nichel satinato.

Il modello con rete alzabile a 2 movimenti presenta il fondo contenitore con alzata per riporre oggetti, sgancio e posizionamento orizzontale per rifare il letto. Sollevamento pistoni 1150 NW. Attenzione: i pistoni del meccanismo di sollevamento rete sono predisposti per alzare la rete con il peso del materasso Kg.35 max (sia per la rete 1600x2000 che per la rete 1800x2000). Utilizzare sempre con materasso appoggiato. Se si toglie il materasso tenere la rete in posizione alzata. Piedi in legno stessa finitura del giroletto.

Il modello con giroletto con rete fissa presenta la rete in legno strutturale con fissati traversi in acciaio verniciato per l'aggancio dei piedi e della testata. Giroletto è in MDF 80x50mm. Spigoli anteriori con inserto in metallo 524 canna di fucile. Piedi in legno con stessa finitura del giroletto.

Il modello con giroletto con rete cliente presenta il giroletto in listellare Sp.38mm. Traversi per appoggio rete in metallo verniciato epossidico e una coppia distanziatori in legno H.25mm. per rialzo reti già compresa nel prezzo. Piedi in legno con stessa finitura del giroletto.

Il letto Giorgia è disponibile nelle finiture essenza opaca Rovere nero, Olmo Grey, Tabacco ed Eucalipto e laccato opaco.

*The bed Giorgia makes elegance comfortable and comodity more versatile.*

*The headboard, consisting of two separate adjustable elements, creates a light curve that gives the night area a delicate sign of style. It is formed of tapered curved plywood panels covered with MDF. Horizontal grooves with slat effect. Rear support panel in melamine faced wood composite panel in same finish of reclining panels 5-position reclining mechanism in galvanised steel. Hinge for rotating reclining panels, in brass with a satin nickel finish.*

*Raisable bedspring with 2 positions, with wood frame and slats: raise to place objects inside, release and horizontal position for making the bed. Raising pistons 1150 NW. Warning: the pistons on the bedspring raising mechanism are designed to raise the bedspring complete with the weight of the mattress Kg.35 max (for both 1600x2000 and 1800x2000 bedsprings). Only use when the mattress is on the bedspring. If the mattress is removed, keep the bedspring in the raised position. Wooden feet in the same finish as the base frame.*

*The model with fixed bed frame has the bed frame made of structural wood with attached painted steel crosspieces for attaching the feet and headboard. Bed frame is made of MDF 80x50mm. Front edges with metal insert 524 gunmetal. Wooden feet same finish as the bedstead.*

*The model with customer bedstead with bedspring has the bedstead in planking Sp.38mm. Crosspieces for bed base support in epoxy painted metal and a pair of wooden spacers H.25mm. for bed base riser already included in the price. Wooden feet same finish as the bedframe.*

*Giorgia bed is available in Black Oak, Grey Elm, Tobacco and Eucalyptus matt essence and matt lacquer finishes.*

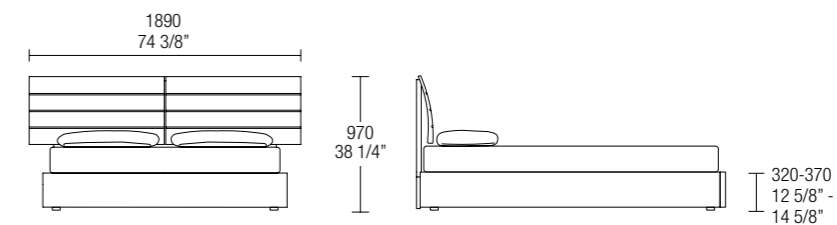
**LETTO CONTENITORE CON RETE FISSA, RETE ALZABILE A 2 MOVIMENTI E RETE CLIENTE**  
**STORAGE BED WITH FIXED BEDSPRING, RAISABLE 2-POSITION BEDSPRING AND CUSTOMER BEDSPRING**

1686	1886
66 3/8"	74 1/4"

**DIM. MATERASSO \_ MATTRESS SIZES**

1600	1800
63"	70 7/8"
<b>A</b>	<b>B</b>

2110	2210
83 1/8"	87"

**DIM. MATERASSO \_ MATTRESS SIZES**

2000	2100
78 3/4"	82 5/8"
<b>A / B</b>	<b>A / B</b>

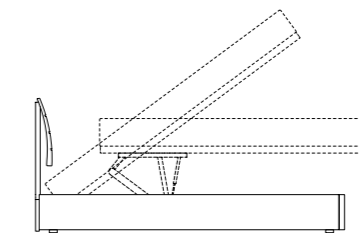
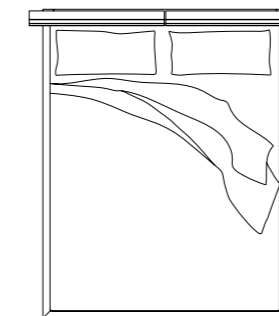

# ELADIO

DESIGN: ROBERTO ALLIEVI E ALBERTO VIGANÒ

Eladio unisce con garbo il calore dell'essenza naturale e la morbidezza delle generose imbottiture: materiali basici, di valore, danno voce al desiderio di creare una struttura rigorosa, testimonianza di un'artigianalità raffinata, ma estremamente accogliente nella sua forma più delicata e poetica.

*Eladio gracefully combines the warmth of natural wood and the softness of generous padding: valuable basic materials express the desire to create a rigorous structure, which demonstrates fine craftsmanship, but is extremely welcoming in its most delicate, poetic form.*







**ELADIO: LETTO \_ BED**

Eladio è un letto accogliente in legno con testiera ammorbidita da cuscini che impiega l'uso di materiali basici di valore.

Struttura in massello sagomato e rifinito a mano disponibile nelle finiture essenza opaca Olmo Grey, Cenere, Rovere nero, Tabacco ed Eucalipto.

La testata è arricchita da due cuscini con laccetti che si ancorano al massello, composti un'anima in poliuretano espanso e materassina in piuma, rivestimenti in tessuto o pelle sfoderabili.

Il letto è compatibile con materassi nelle dimensioni 1600 / 1800 cm.

Adatto per essere posizionato in centro stanza grazie alla meticolosa attenzione dei dettagli in ogni suo lato.

*Eladio is a cozy wooden bed with a headboard softened by cushions, using basic yet valuable materials.*

*The structure is made of shaped solid wood, hand-finished, and available in matt wood finishes of Grey Elm, Cenere, Black Oak, Tobacco, and Eucalyptus.*

*The headboard is enhanced by two cushions with ties that anchor to the solid wood frame. These cushions feature a polyurethane foam core and a feather mattress, with removable fabric or leather covers.*

*The bed is compatible with mattresses measuring 1600 / 1800 mm.*

*It is suitable for placement in the center of the room, thanks to meticulous attention to detail on every side.*

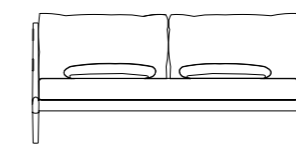
**LETTO IN LEGNO CON CUSCINI DI TESTATA E RETE PIANA D'APPOGGIO DEDICATA \_ WOODEN BED WITH CUSHIONS AND DEDICATED FLAT SEPARATE BEDSPRING**

900  
35 3/8"

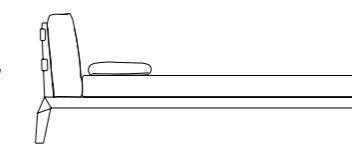

320  
12 5/8"

1690 | 1890  
66 1/2" | 74 3/8"

**DIM. MATERASSO \_ MATTRESS SIZES**

1600 | 1800  
63" | 70 7/8"

2320  
91 3/8"

**DIM. MATERASSO \_ MATTRESS SIZES**

2000  
78 3/4"

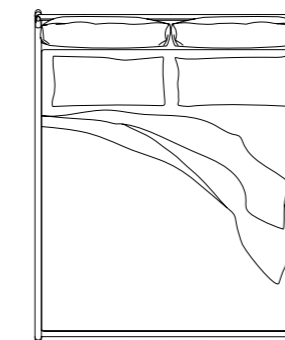

## COMPLEMENTI NOTTE NIGHT COMPLEMENTS

Semplice, ricercato, di design, il gruppo notte è un oggetto che affascina. Tradizionale o attento alle tendenze, sobrio o trasgressivo, può rispecchiare la tua personalità. Complemento fondamentale in camera da letto, che completa e valorizza la camera.

*Night stands are subjects that fascinate with simple and sophisticated design. Traditional or sensitive to trends, sober or avant-garde, they can reflect your personality. An essential complement to the bedroom, they enhance and emphasizes a project.*



**Eros**  
Studio63

—  
340



**Milvian Night**  
Francesco Lucchese

—  
346



**Lindo**  
Carlo Marelli e Massimo Molteni

—  
352



**Cube**  
CR&S MisuraEmme

—  
358



**Shanghai**  
Mauro Lipparini

—  
362

# EROS

DESIGN: STUDIO63

Il gruppo notte Eros, formato da comò e comodino, si contraddistingue per il sofisticato dialogo tra i diversi materiali che lo compongono: metallo, marmo, legno. La struttura sostiene un pregiato piano di appoggio attraverso una sofisticata rientranza all'interno della quale è inserita. Il contenitore è come sospeso tra il top e il pavimento risultando leggero ed etereo.

*The Eros night group, consisting of a chest of drawers and bed side table, is characterized by the sophisticated dialogue between the different materials that compose it: metal, marble, wood. The structure holds a precious surface through a sophisticated recess inside which it is inserted. The container is suspended between the top and the floor, making it light and ethereal.*



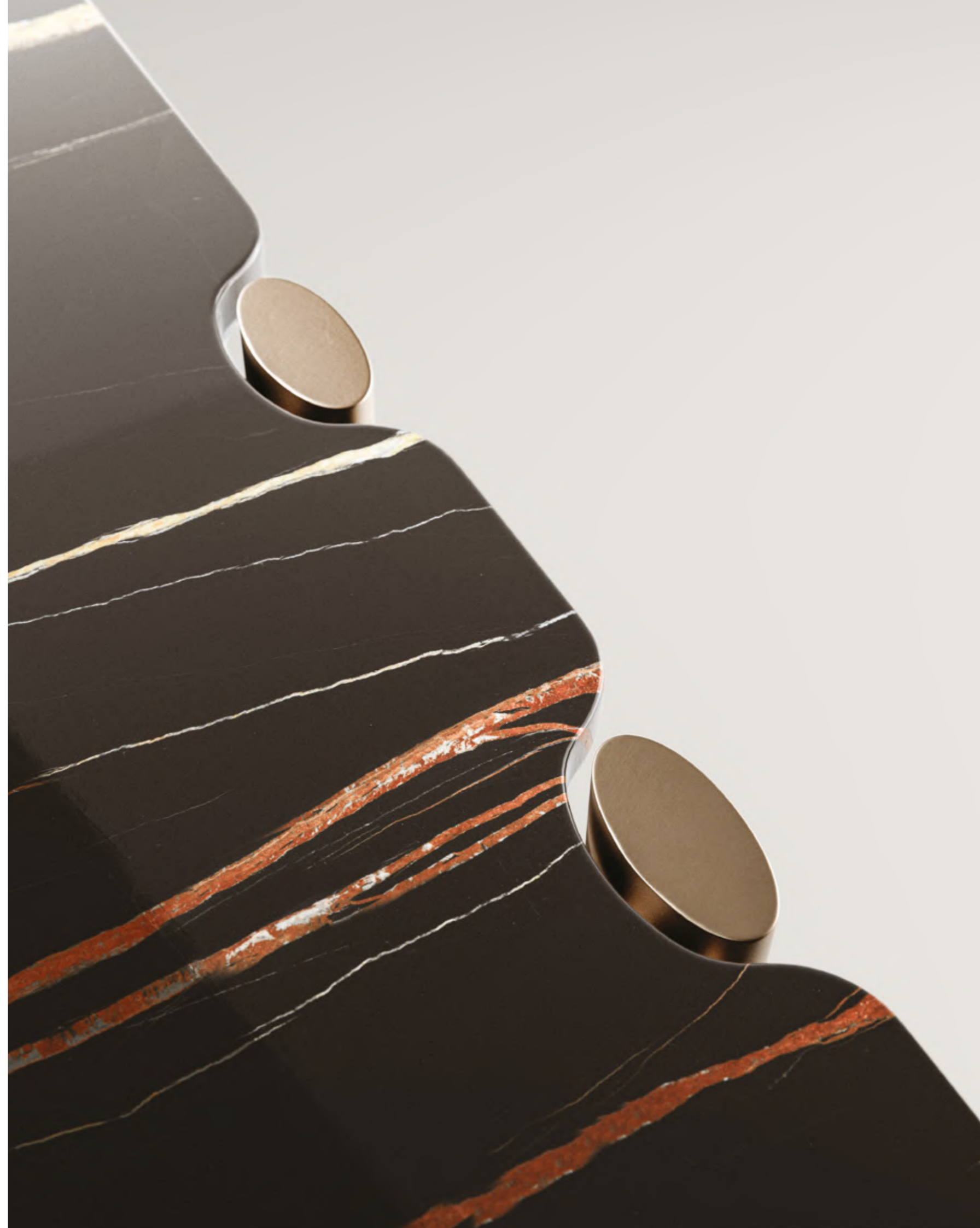

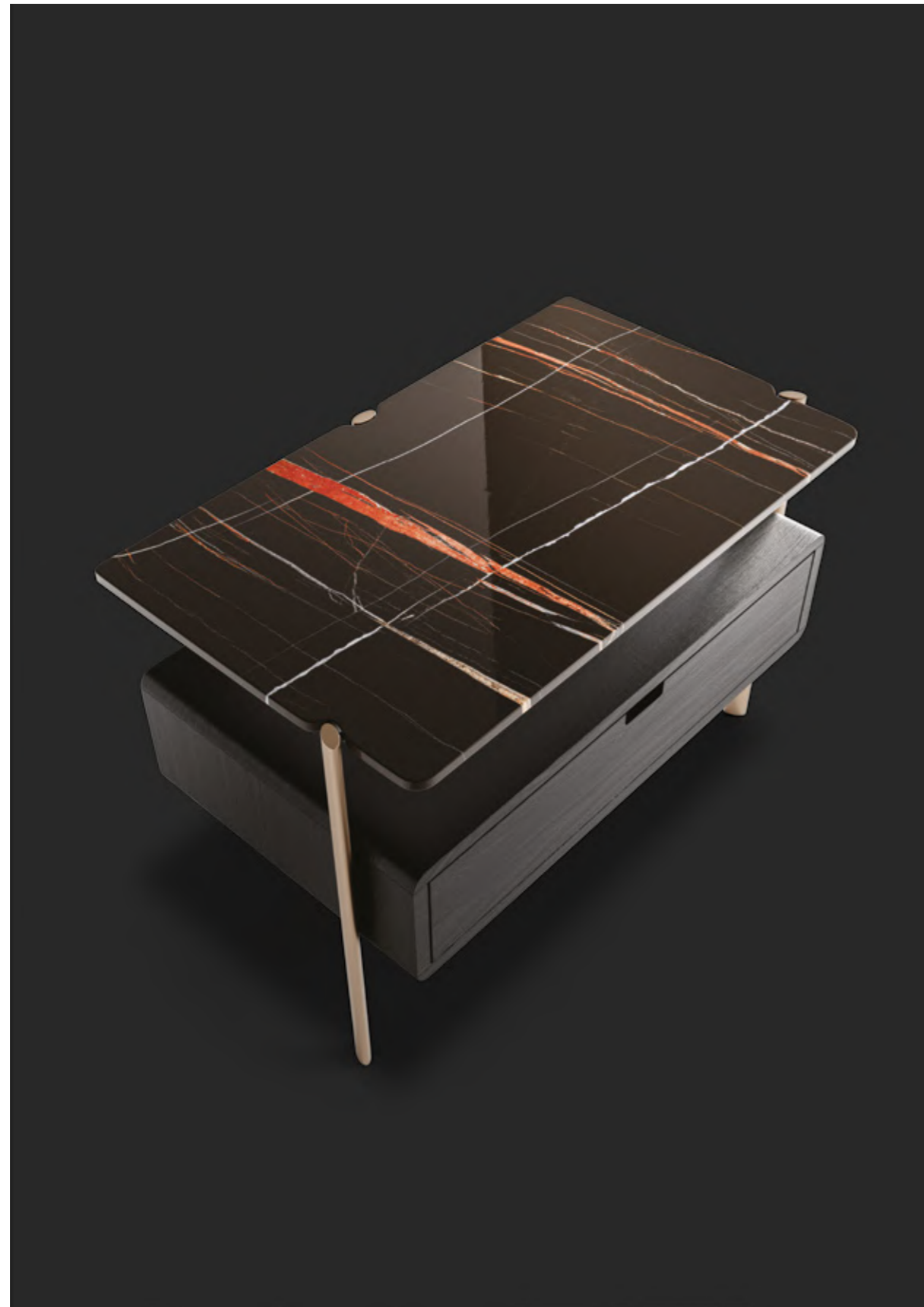

---

**EROS: GRUPPO NOTTE \_ NIGHT STAND**

Il gruppo notte Eros contraddistinto dal sofisticato dialogo tra i diversi materiali: metallo, marmo, legno, è composto da un comò e comodini di due diverse dimensioni L. 500 mm e L. 700 mm. La struttura di diametro ovale metallico, disponibile in tutte le finiture metallizzate lucide e opache, sostiene i cassetti in essenza Rovere nero con guide soft closing ad estrazione totale. L'interno dei cassetti è in melaminico Primo Fiore.

Il piano è caratterizzato da una sofisticata rientranza all'interno della quale è inserita la struttura in metallo ed è disponibile in tutte le varianti del marmo sp. 20 mm.

*The Eros night group, distinguished by the sophisticated interplay of different materials: metal, marble, and wood, consists of a chest of drawers and nightstands in two sizes: L. 500 mm and L. 700 mm. The structure, with an oval metal frame is available in all glossy and matt metallic finishes. It supports drawers in Black Oak with soft-closing guides and full-extension slides. The interior of the drawers is made of Primo Fiore melamine.*

*The top is characterized by a sophisticated recessed area, within which the metal structure is inserted. It is available in all variations of marble th.20 mm.*

---

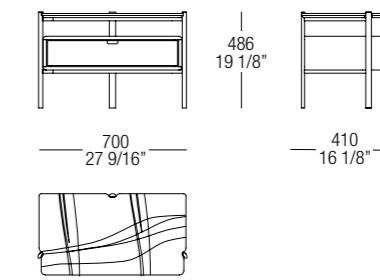
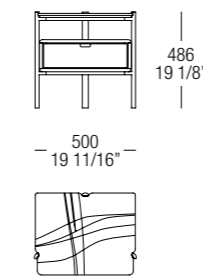
**COMODINO A 1 CASSETTO / NIGHT TABLE WITH 1 DRAWER**

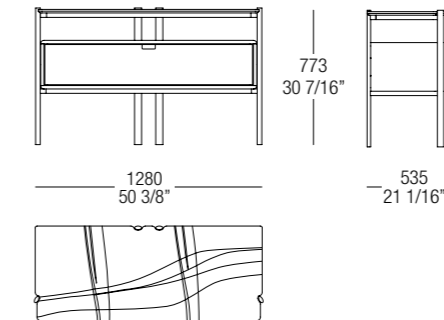

---

**COMÒ A 1 CASSETTO / CHEST WITH 1 DRAWER**

# MILVIAN NIGHT

DESIGN: FRANCESCO LUCCHESI

Sublimi suggestioni di gusto ricercato per il gruppo notte Milvian, composto da comodini a due larghezze e comò. Originale fusione di esclusive linee e dettagli costruttivi di pregio, la struttura in essenza viene incorniciata dalle spalle sagomate che proseguono fino a terra trasformandosi in garbati piedini. L'estetica, esaltata dal prezioso top in essenza disponibile in numerose finiture, non perde di vista la funzionalità: alla versione con cassetto e vano si accosta quella con frontale fisso, perfetta per un utilizzo bifacciale.

Un equilibrio sapiente e un legame coordinato per la zona notte.

*The Milvian set for the night area, which consists of bedside tables in two different sizes and a dresser, boasts sublime features with a sophisticated style. An original fusion of exclusive designs and exquisite construction details, the structure which comes in oak is framed by shaped shoulders that continue down to the ground, transforming into graceful feet. The aesthetic, which is enhanced by the fine wooden top available in numerous finishes, does not undermine its functionality: the version with a drawer and compartment resembles the version with the fixed front, which is perfect for two-sided use. A tasteful balance and a coordinated bond for the night area.*







**MILVIAN NIGHT: GRUPPO NOTTE \_ NIGHT STAND**

Il gruppo notte Milvian è composto da un comò e comodini di due diverse dimensioni L.710 mm e L. 870 m. Disponibili anche le versioni con frontale fisso per utilizzo bifacciale (profondità 516 mm) o parete (profondità 504 mm).

Le spalle sono sagomate in alluminio verniciato opaco bronzo o canna di fucile, i cassetti in essenza opaca, lucida sono disponibili nelle finiture Rovere nero, Olmo Grey, Tabacco ed Eucalipto e hanno le guide soft closing ad estrazione totale con l'interno in nobilitato Primo Fiore.

Il top del comodino è disponibile in vetro trasparente extra chiaro o trasparente fumè sp.12mm, invece, il top del comò è disponibile in essenza opaca o lucida sp.19 mm o in marmo tutte le varianti sp.20 mm.

*The Milvian night group consists of a chest of drawers and nightstands in two sizes: L.710 mm and L.870 mm. Available also with fixed fronts for dual-sided use (deep 516 mm \_ 20 5/16") or to wall (deep 504 mm \_ 19 13/16").*

*The sides are shaped from matt lacquered aluminum in either Bronze or Gunmetal finishes. The drawers, available in matt or glossy wood finishes, come in Black Oak, Grey Elm, Tobacco and Eucalyptus, and feature soft-closing guides with full extension. The interior of the drawers is made of Primo Fiore melamine.*

*The nightstand top is available in transparent extra-light or fumè transparent glass with a th.12 mm, while the chest of drawers top is available in either matt glossy wood finishes th.19 mm or in marble in all variations th.20 mm.*

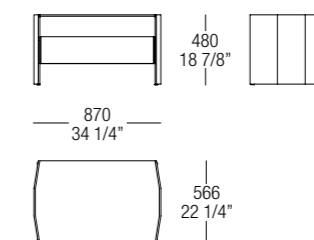
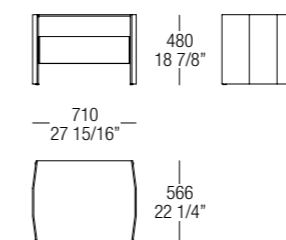
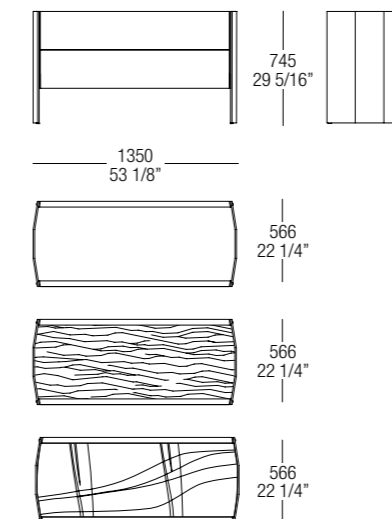
**COMODINO A 1 CASSETTO \_ NIGHT TABLE WITH 1 DRAWER**

**COMÒ A 2 CASSETTI \_ CHEST WITH 2 DRAWERS**

# LINDO

DESIGN: CARLO MARELLI E MASSIMO MOLTENI

Il suo è un design senza tempo, sospeso tra essenzialità contemporanea e fasti che riaffiorano. Il piano in marmo, si innesta al capiente cassetto con frontale sagomato. A sostenere le esili ma solide gambe in metallo, che incorniciano un sottile e prezioso piano di appoggio.

*Timeless design, among contemporary simplicity and splendor that re-emerge.  
The marble top insets into the large capacity shaped front drawer.  
Thin metal legs are framed by a precious shelf.*



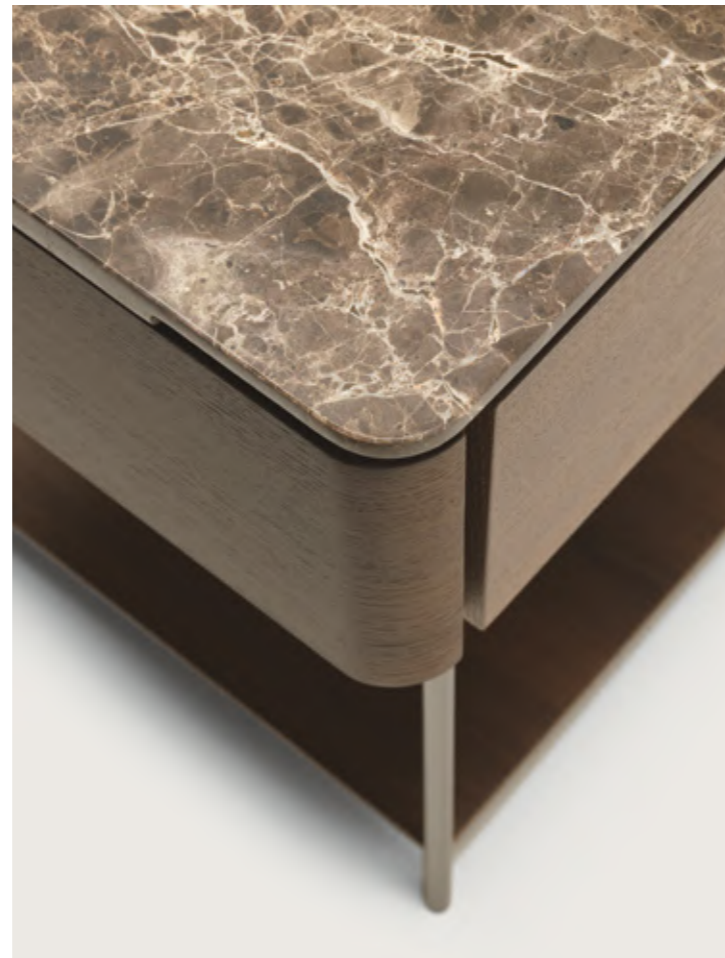

**LINDO: GRUPPO NOTTE \_ NIGHT STAND**

Il gruppo notte Lindo è composto da un comò a 6 cassetti e un comodino.

Entrambi hanno la struttura in essenza attrezzata con un cassetto con frontale sagomato e con guide soft closing ad estrazione totale. Struttura esterna in essenza Eucalipto, Tabacco e Rovere nero e struttura interna in melaminico Primo fiore.

Il top sagomato è disponibile in marmo tutte le varianti sp. 20 mm o in essenza Rovere nero, Eucalipto e Tabacco sp. 20 mm.

Il comodino è dotato di una base in metallo verniciato opaco Canna di fucile con ripiano inferiore in appoggio sp. 8 mm. in essenza Rovere nero, Eucalipto e Tabacco.

*The Lindo night group consists of a 6-drawer chest of drawers and a nightstand.*

*Both have a structure in wood, equipped with a drawer featuring a shaped front and soft-closing full-extension guides. The external structure is available in Eucalyptus, Tobacco, and Black Oak finishes, while the interior structure is made of Primo fiore melamine.*

*The shaped top is available in marble in all variations th.20 mm. or in wood finishes of Black Oak, Eucalyptus, and Tobacco th.20 mm.*

*The nightstand features a base in matt lacquered Gunmetal with a lower shelf in wood th.8 mm. available in Black Oak, Eucalyptus, and Tobacco.*

**COMODINO A 1 CASSETTO \_ NIGHT TABLE WITH 1 DRAWER**

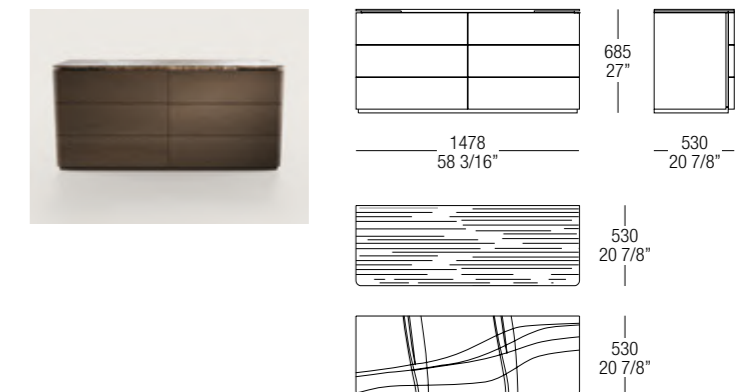
**COMÒ A 6 CASSETTI \_ CHEST WITH 6 DRAWERS**

# CUBE

DESIGN: CR&S MISURAEMME

La serie di comò e comodini Cube è un progetto che combina sapientemente essenze, lacche e vetro. Il top è leggermente ribassato rispetto alla struttura e va a formare un raffinato vassoio d'appoggio.

*Various chests of drawers and bedside units Cube, that intelligently combine wood, lacquer and glass. The top is lowered with respect to the structure to resemble a tray.*





**CUBE: GRUPPO NOTTE \_ NIGHT STAND**

Il gruppo notte Cube è composto da un comò a 4 cassetti e un comodino. Entrambe le strutture sono composte da MDF sp. 14 mm rivestito in laccato opaco o essenza Rovere nero, Eucalipto, Ebano, Noce Canaletto, Cenere, Tabacco e Olmo Grey.

I cassetti sono dotati di guide soft closing ad estrazione totale e la finitura al loro interno è in nobilitato Primo Fiore. Il top è ribassato rispetto la struttura come a formare un vassoio con rifinitura legno, vetro verniciato o vetro verniciato acidato.

*The Cube night group consists of a 4-drawer chest of drawers and a nightstand. Both structures are made of 14 mm thick MDF, covered in matt lacquer or wood finishes such as Black Oak, Eucalyptus, Ebony, Noce Canaletto, Cenere, Tobacco, and Elm Grey.*

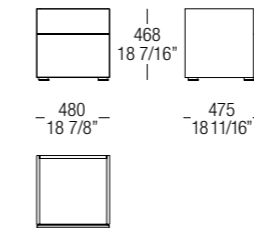
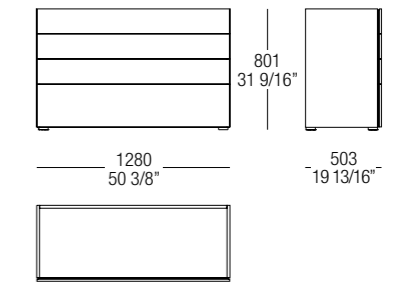
*The drawers are equipped with soft-closing full-extension guides, and the interior finish is in Primo Fiore melamine. The top is recessed compared to the structure, forming a tray, and is available with wood, painted glass, or etched painted glass finishes.*

**COMODINO A 2 CASSETTI \_ NIGHT TABLE WITH 2 DRAWERS**

**COMÒ A 4 CASSETTI \_ CHEST WITH 4 DRAWERS**

# SHANGHAI

DESIGN: MAURO LIPPARINI

Shanghai è un comodino dalle dimensioni discrete, un isola geometricamente pura per l'intorno del dormire. Le gambe hanno una struttura esile, come a voler sospendere il volume. Base in metallo canna di fucile. Struttura contenitore in tubolare rivestito in rovere. Sotto il piano del comodino è disponibile una luce led di cortesia.

*Shanghai is a bedside unit with discrete dimensions, a geometrically pure island for the night area. With slender structured legs as if to suspend the volume. Base in gun metal finish. Structure container in tubular covered in oak. A light is available to position underneath the top of the bedside unit.*







---

**SHANGHAI: GRUPPO NOTTE \_ NIGHT STAND**

Comodino Shanghai con struttura in multistrato curvato tubolare rivestita in essenza Rovere nero, Olmo Grey, Eucalipto e Tabacco. Base in tubolare di metallo verniciato opaco canna di fucile. Cassetto con guide invisibili in acciaio soft closing con interno in nobilitato Primo Fiore. Finitura top laccato opaco disponibile in tutte le varianti.

*Shangai nightstand with structure made of curved tubular plywood, covered in wood finishes such as Black Oak, Grey Elm, Eucalyptus, and Tobacco. The base is made of matt lacquered Gunmetal tubular metal. The drawer features invisible steel soft-closing guides, with an interior in Primo Fiore melamine. The top finish is in matt lacquer, available in all variants.*

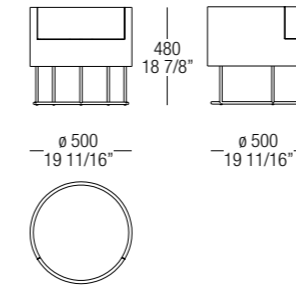
---

**COMODINO A 1 CASSETTO \_ NIGHT TABLE WITH 1 DRAWERS**



# ACCESSORI ACCESSORIES

Un alfabeto di elementi distinti e funzionali che incarnano l'importanza della semplicità nella quotidianità. Oggetti di uso quotidiano si trasformano in complementi di pregio che arricchiscono con armonia l'ambiente portando la propria originalità.

*An alphabet of distinct and functional elements that embodies the importance of simplicity in everyday life. Everyday objects transform into refined complements that enrich the environment with harmony, bringing their own originality.*



**Irving**  
Studio63

—  
368



**Denver**  
Studio63

—  
372



**Virgin pouf**  
Mauro Lipparini

—  
376



**Stone**  
CR&S MISURAEMME

—  
380



**Orville e Penelope**  
CR&S MISURAEMME

—  
384



**Clovis e Alison**  
CR&S MISURAEMME

—  
392

# IRVING

DESIGN: STUDIO 63

Il servomuto Irving deriva dalla filosofia e dalla penna dello Studio63 che ci ricorda l'importanza delle piccole cose nella quotidianità. "Il mondo è pieno di oggetti ma spesso ci dimentichiamo di ciò che è davvero importante". Questo elemento pratico viene reso estremamente elegante e di design grazie alla scelta di materiali pregiati come la struttura in metallo verniciato Canna di Fucile lucido e il piano poggia-scarpe in marmo.

*The Irving valet stand derives from the philosophy and pen of Studio63, reminding us of the importance of small things in everyday life.*

*"The world is full of objects, but often we forget what is really important".*

*This practical item is rendered extremely elegant and designer thanks to the choice of precious materials such as the glossy gunmetal painted metal structure and the shoe-resting top in marble.*







---

**IRVING: SERVOMUTO \_ VALET STAND**

Servomuto Irving caratterizzato da una sottile struttura con sezione ellittica in metallo verniciato lucido o opaco, svuotatasche rivestito in pelle e piano di appoggio in marmo disponibile in tutte le varianti.

*Irving valet stand characterized by a slim structure with an elliptical section in glossy or matt varnished metal, a leather-covered tray, and a marble top available in all variants.*

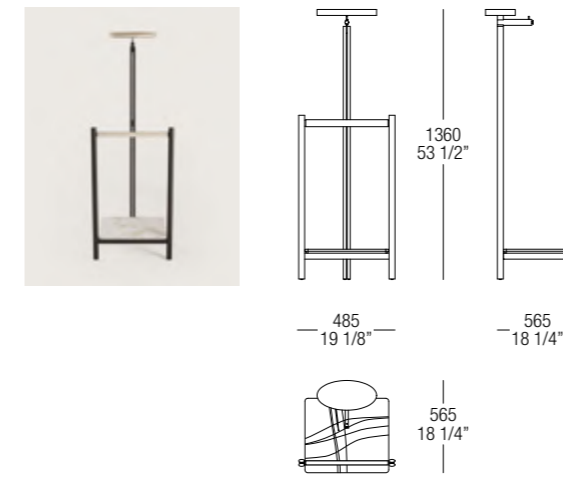
---

**SERVOMUTO \_ VALET STAND**

# DENVER

DESIGN: STUDIO 63

Il portagiornali Denver incarna la funzionalità con eleganza. Un elemento pratico e raffinato, ideale per mantenere l'ordine e l'organizzazione nello spazio living.

La struttura tubolare in metallo verniciato viene arricchita dalla lavorazione manuale dell'intreccio della pelle, che funge da supporto per i giornali.

*The Denver magazine rack embodies functionality with elegance. A practical and refined element, ideal for maintaining order and organization in the living space.*

*The tubular structure in painted metal is enriched by the handcrafted of leather weaving, which serves as a support for magazines.*







---

**DENVER:** PORTAGIORNALI \_ MAGAZINE RACK

Portagiornali Denver con struttura con sezione ellittica in metallo verniciato lucido o opaco. Il rivestimento è caratterizzato dalla pelle nera Primalinea intrecciata.

*Denver magazine rack with elliptical metal section structure, available in glossy or matt metal finish. The upholstery features woven black Primalinea leather.*

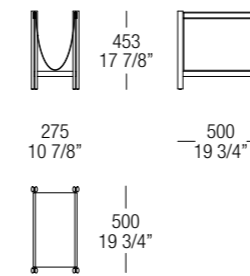
---

 PORTAGIORNALI \_ MAGAZINE RACK

# VIRGIN

DESIGN: MAURO LIPPARINI

Caratteristica di tutta la collezione è la morbidezza che si realizza in un elegante e colto recupero di linee morbide anni 50 e che prevede una sezione ellittica nella forma del pouf. Contrasto tra esile e massiccio, tra i piedi filiformi e l'imbottito corposo dal rassicurante appoggio.

*Characteristic of the whole collection is the softness that is achieved in an elegant and cultured recovery of soft lines of the 50s and which provides an elliptical section in the shape of the pouf. Contrast between slender and massive, between the threadlike feet and the full-bodied upholstery with reassuring support.*



**VIRGIN: POUF**

Pouf Virgin a due dimensioni con struttura interna in legno rivestita da gomma comfort. Rivestimento tessuto sfoderabile con velcro, in pelle sfoderabile da personale specializzato e non disponibile in ecopelle e velluto. Base con sezione circolare in metallo verniciato nero.

*Virgin pouf available in two sizes with an internal wooden structure covered with comfort foam. Removable fabric upholstery with Velcro, or removable leather upholstery, by specialized personnel; not available in eco-leather or velvet. Base with a circular section in black varnished metal.*

## POUF

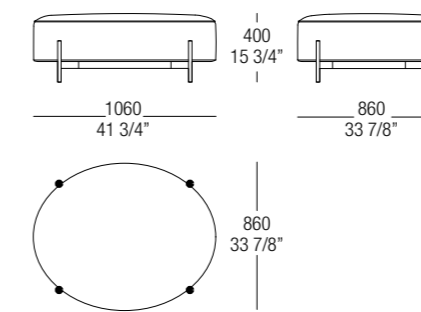
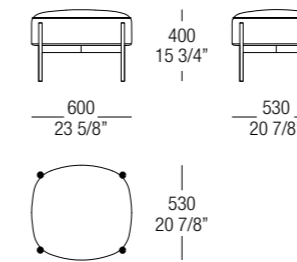

# STONE

DESIGN: CR&S MISURAEMME

La collezione di Pouf Stone celebra la semplicità delle forme essenziali: quadrate, circolari e rettangolari. Disponibili in sette dimensioni, si adattano con eleganza a ogni spazio, valorizzando materiali pregiati come tessuto, pelle, ecopelle e velluto. Design minimale e comfort assoluto in perfetto equilibrio.

*The Pouf Stone collection celebrates the simplicity of essential shapes: square, circular, and rectangular. Available in seven sizes, they elegantly adapt to any space, enhancing fine materials such as fabric, leather, eco-leather, and velvet. Minimal design and absolute comfort in perfect harmony.*







**STONE: POUF**

Pouf Stone a sette dimensioni con struttura interna in legno rivestita da gomma comfort. Rivestimento tessuto sfoderabile con velcro, non sfoderabile in pelle, ecopelle e velluto.

*Seven-size Stone pouf with an internal wooden structure covered with comfort foam. Removable fabric cover with velcro, non-removable in leather, eco-leather, and velvet.*

**POUF**

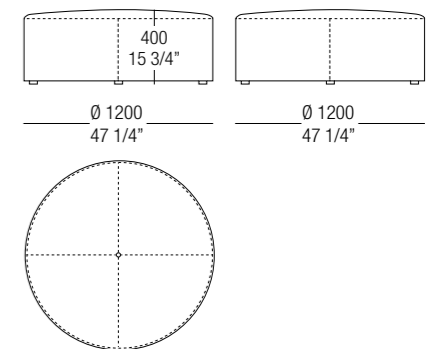
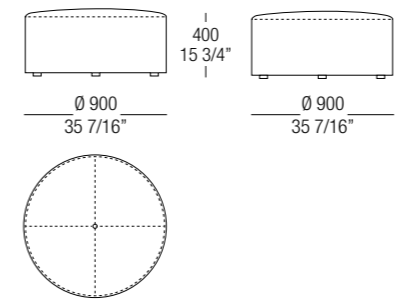
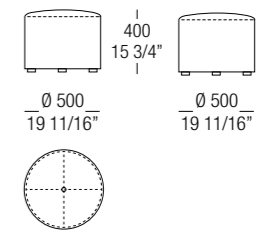
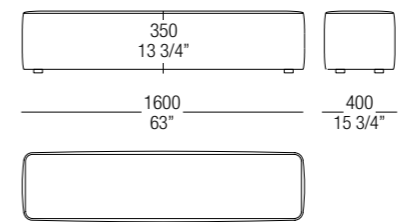
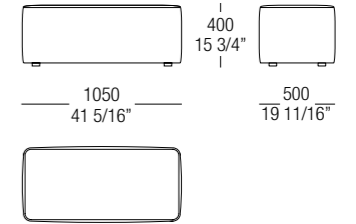
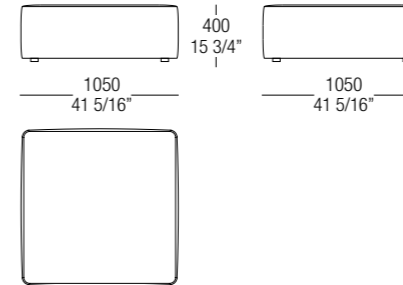
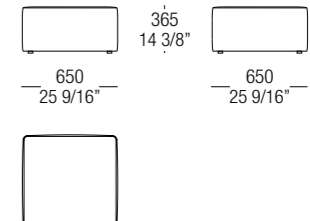
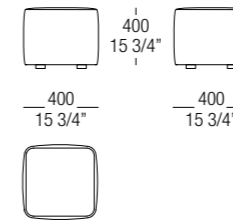

# ORVILLE

DESIGN: CR&S MISURAEMME

Tappeto caratterizzato da un disegno essenziale e contemporaneo, contraddistinto da linee sinuose e dai toni bicolor, Orville rappresenta un complemento d'arredo raffinato e dal linguaggio universale. Dal living all'hospitality, dal retail al contract, Orville permette di valorizzare ogni ambiente e contesto con il tocco dell'inconfondibile stile MisuraEmme.

*Orville is a rug characterized by an essential and contemporary design, featuring sinuous lines and bicolor tones, it represents a refined complement of furniture and universal language. From living spaces to hospitality, from retail to contract, Orville allows you to enhance every environment and context with the touch of the unmistakable MisuraEmme style.*



**ORVILLE:** TAPPETO \_ RUG

Orville, tappeto dall'aspetto vellutato caratterizzato da linee sinuose e tagli bicolore. Composizione poliammidica con sottofondo di Juta, disponibile nelle moquette: Aladin, un tappeto che regala uno stato di assoluto comfort e benessere, attutisce il suono dei propri passi e al contempo dona personalità agli ambienti con le sue peculiarità cromatiche ed estetiche, con spessore di 16mm e composizione 100% poliammidica. Bliss caratterizzato da una tessitura soffice e ricca, con spessore 21,5 mm e composizione 100% poliestere. Le dimensioni sono variabili e disponibili su misura.

*Orville, a velvety rug featuring sinuous lines and bicolor cuts. Made from polyamide with a jute backing, available in the carpets: Aladin, a rug that provides an absolute sense of comfort and well-being, dampening the sound of footsteps while adding personality to spaces with its distinctive colors and aesthetics, with a thickness of 16mm and 100% polyamide composition. Bliss, characterized by a soft and rich weave, with a thickness of 21.5mm and 100% polyester composition. Dimensions are variable and available made-to-measure.*

## TAPPETO \_ RUG

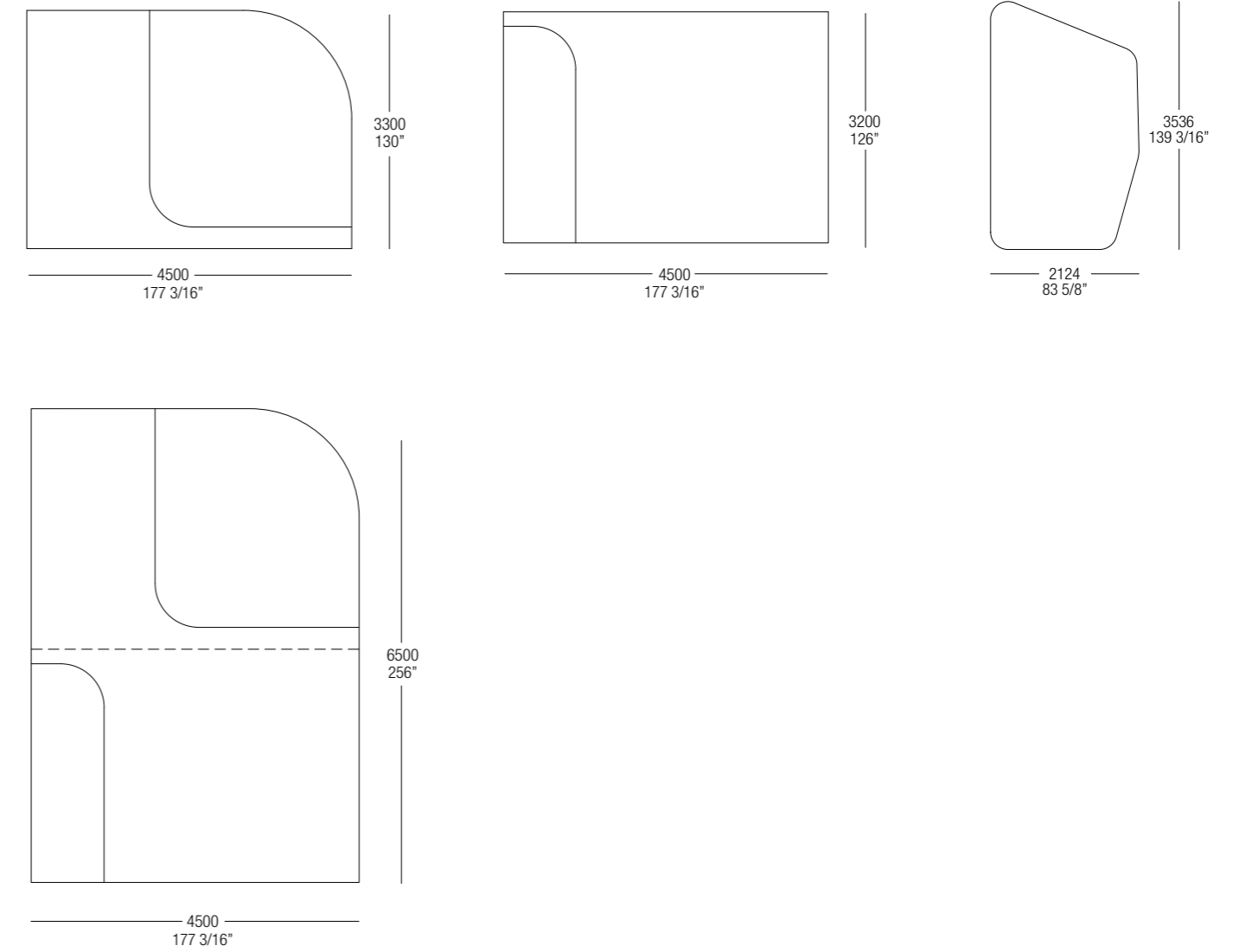

# PENELOPE

DESIGN: CR&S MISURAEMME

Tappeto caratterizzato da abbinamenti cromatici nei toni del legno e della terra, Penelope è il complemento d'arredo ideale per ambienti sia contemporanei sia moderni. Le sue linee geometriche e regolari, eleganti e dalla personalità decisa, costituiscono la sintesi del total look MisuraEmme.

*A rug characterized by smooth color combinations in wood and earth smooth color, Penelope is the ideal piece of furniture for contemporary and modern settings. Its geometric and regular lines, elegant and with a strong personality, constitute the synthesis of the MisuraEmme total look.*

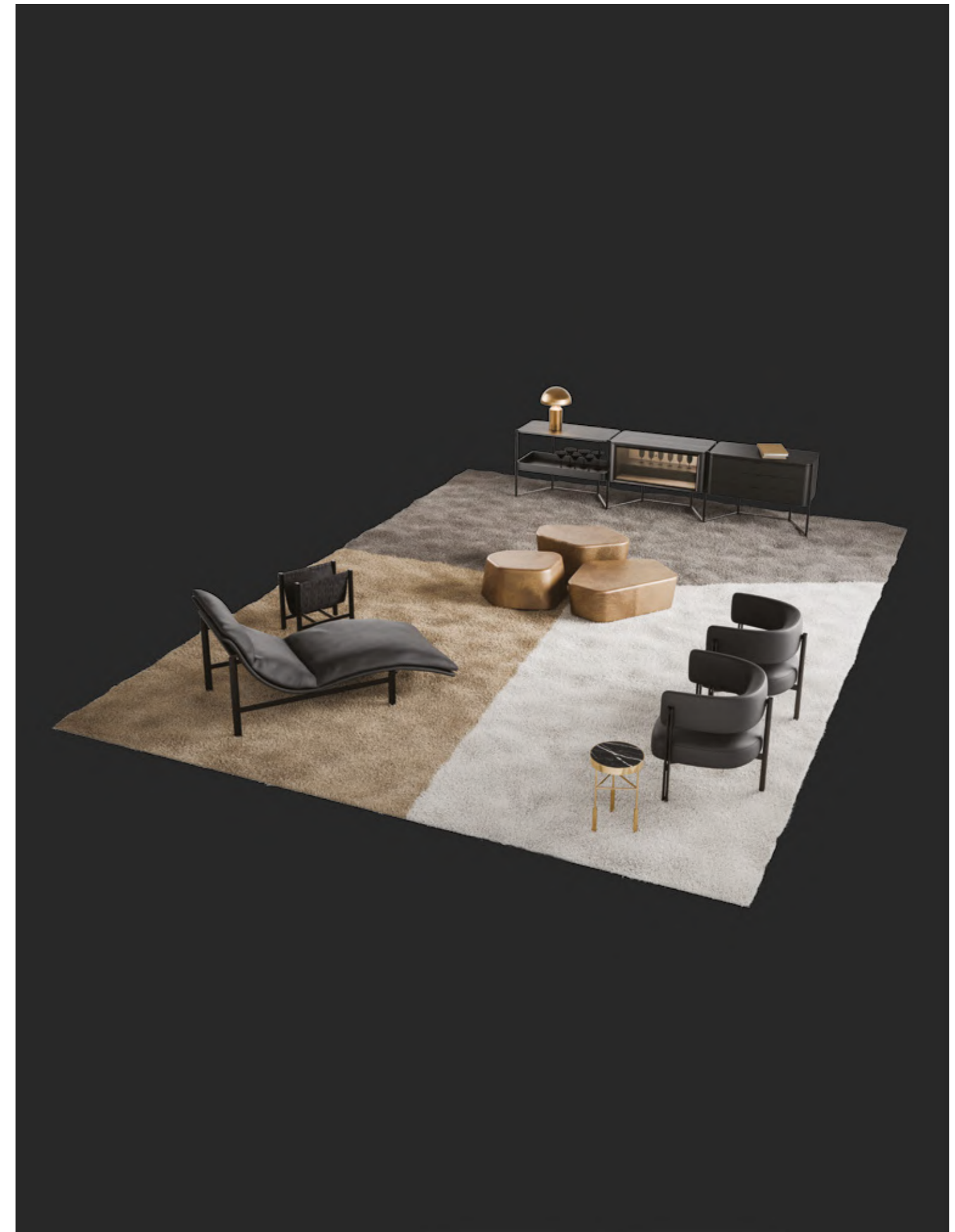





---

**PENELOPE: TAPPETO \_ RUG**

Tappeto Penelope dall'aspetto vellutato caratterizzato da linee rette e geometriche che giocano con tagli e abbinamenti di colori. La sua forma ricorda la tessitura della tela di Penelope. Composizione poliammidica con sottofondo di Juta, disponibile nelle moquette: Aladin, un tappeto che regala uno stato di assoluto comfort e benessere, attutisce il suono dei propri passi e al contempo dona personalità agli ambienti con le sue peculiarità cromatiche ed estetiche, con spessore di 16mm e composizione 100% poliammidica. Bliss caratterizzato da una tessitura soffice e ricca, con spessore 21,5 mm e composizione 100% poliestere. Le dimensioni sono variabili e disponibili su misura.

*Penelope, a velvety rug featuring straight, geometric lines that play with cuts and color combinations. Its shape recalls the texture of Penelope's web. Made from polyamide with a jute backing, available in the carpets: Aladin, a rug that offers absolute comfort and well-being, muffling the sound of footsteps while adding personality to spaces with its distinctive colors and aesthetics, with a thickness of 16mm and 100% polyamide composition. Bliss, characterized by a soft and rich weave, with a thickness of 21.5mm and 100% polyester composition. Dimensions are variable and available made-to-measure.*

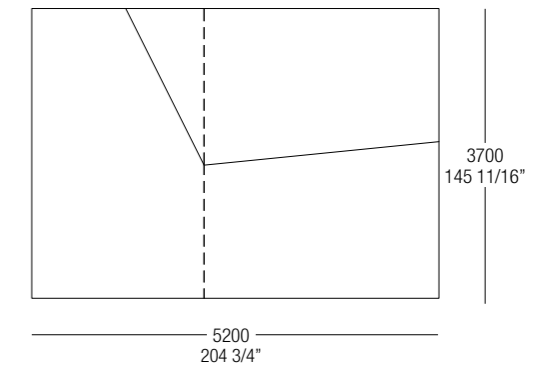
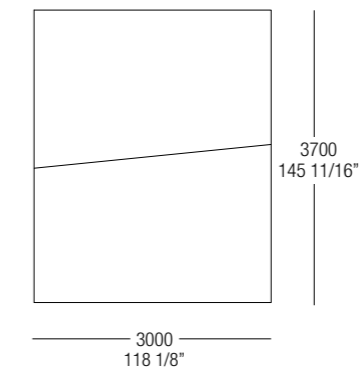
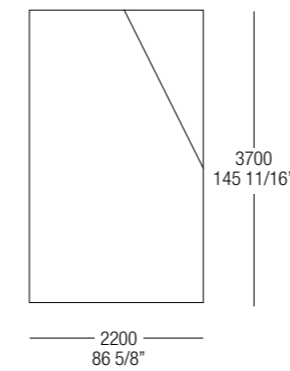
---

**TAPPETO \_ RUG**

# CLOVIS

DESIGN: CR&S MISURAEMME

Il comfort avvolge la collezione di cuscini Clovis, contraddistinta da eleganza e calore in ogni dettaglio, con bande che esaltano la tua personalità. Morbidi e raffinati, grazie all'imbottitura accogliente e ai preziosi rivestimenti, questi cuscini aggiungono un tocco di classe e personalità ad ogni ambiente.

*Comfort envelops the Clovis cushion collection, distinguished by elegance and warmth in every detail, with bands that enhance your personality. Soft and refined, thanks to the cozy padding and luxurious covers, these cushions add a touch of class and character to any space.*







---

**CLOVIS: CUSCINO \_ CUSHION**

Collezione di cuscini Clovis di 3 dimensioni caratterizzati da una banda che percorre tutto il perimetro. Imbottiture in Multi Fill e rivestimento sfoderabile in tessuto, pelle o ecopelle con possibilità di trapuntatura per le finiture pelle e Nabuk.

*Clovis cushions collection available in 3 sizes, characterized by a band that runs along the entire perimeter. Featuring Multi Fill padding and removable covers in fabric, leather, or eco-leather, with the option of quilting for leather and Nabuk finishes.*

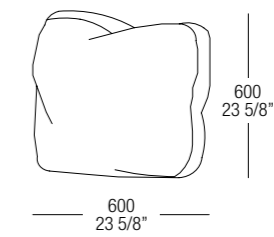
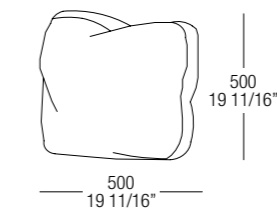
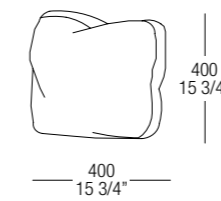
---

**CUSCINO \_ CUSHION**

# ALISON

DESIGN: CR&S MISURAEMME

Alison è il comfort esclusivo di una collezione di cuscini pensata per ogni esigenza, spazio e utilizzo. Si adatta ad ogni ambiente ed è arricchita da una palette cromatica sofisticata che personalizza le stanze. Un tocco di eleganza e calore che rende unico ogni momento di relax.

*Alison is the exclusive comfort of a cushion collection designed for every need, space, and use. It adapts to any environment and is enhanced by a sophisticated color palette that personalizes rooms. A touch of elegance and warmth that makes every moment of relaxation unique.*









---

**ALISON: CUSCINO \_ CUSHION**

Collezione di cuscini Alison di 4 dimensioni con imbottitura in piuma o in espanso e rivestimento sfoderabile in tessuto, pelle o ecopelle con possibilità di trapuntatura.

*Alison cushions collection available in 4 sizes, with feather or foam padding and a removable cover in fabric, leather, or eco-leather, with the option of quilting.*

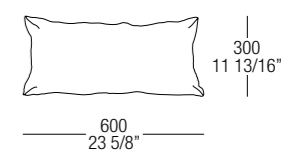
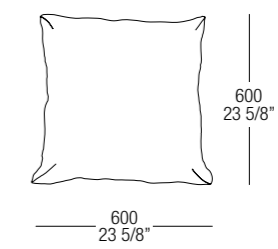
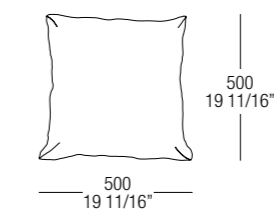
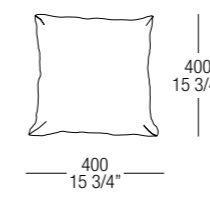
---

**CUSCINO \_ CUSHION**

Concept, art direction  
**MisuraEmme®** studio

Photography  
**Michele Poli Mascheroni**

Styling  
**MisuraEmme®** studio

Printing  
**Grafiche Antiga**

Copyright  
**MisuraEmme®**

Thanks to  
**NAHOOR**  
**QU**



The mark of  
responsible forestry

Cerca prodotti certificati  
FSC®



Made in Italy - OABOBE

**MisuraEmme® S.p.A.**  
Via IV Novembre, 72  
22066 Mariano Comense (CO)  
Tel. +39 031.754111  
Fax. +39 031.744437  
info@misuraemme.it  
**www.misuraemme.it**

MisuraEmme® si riserva il diritto di apportare ogni modifica mirata al miglioramento funzionale e qualitativo dei propri prodotti.  
Testi e disegni presenti in questo stampato hanno scopo divulgativo, per ogni aspetto tecnico e dimensionale fare riferimento ai listini aziendali e relativi aggiornamenti.

MisuraEmme® reserves the right at all time to apply modifications for the functional or qualitative improvement of its products. Text and drawings present in this brochure have a divulgative purpose, for every technical and dimensional aspect please refer to the company's price lists and their relative updatings.